

# TURN SIGNAL AND HAZARD WARNING LIGHTS

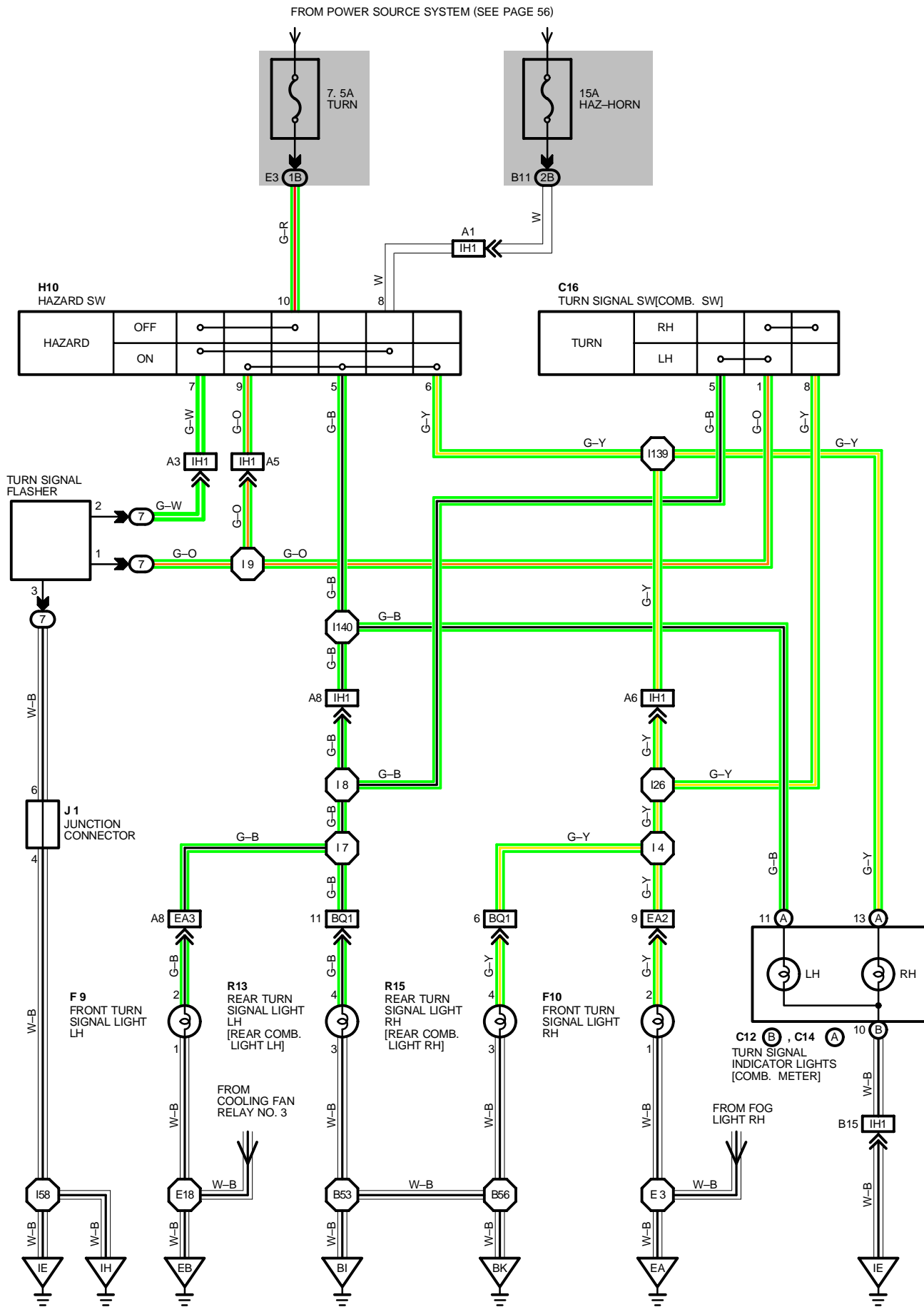

## SERVICE HINTS

### T12 TURN SIGNAL FLASHER

- (7) 1-GROUND : CHANGES FROM APPROX. 12 VOLTS TO 0 VOLTS WITH IGNITION SW ON AND TURN SIGNAL SW LEFT OR RIGHT, OR WITH HAZARD SW ON  
 (7) 2-GROUND : APPROX. 12 VOLTS WITH IGNITION SW ON OR HAZARD SW ON  
 (7) 3-GROUND : ALWAYS CONTINUITY

### ○ : PARTS LOCATION

CODE	SEE PAGE	CODE	SEE PAGE	CODE	SEE PAGE	
C12	B	26	F 9	24	J 1	27
C14	A	26	F10	24	R13	29
C16	26	H10	26	R15	29	

### ○ : RELAY BLOCKS

CODE	SEE PAGE	RELAY BLOCKS (RELAY BLOCK LOCATION)
7	16	R/B NO.7 (RIGHT SIDE OF J/B NO.1)

### ○ : JUNCTION BLOCK AND WIRE HARNESS CONNECTOR

CODE	SEE PAGE	JUNCTION BLOCK AND WIRE HARNESS (CONNECTOR LOCATION)
1B	18	INSTRUMENT PANEL WIRE AND J/B NO.1 (LEFT SIDE OF STEERING COLUMN TUBE)
2B	20	COWL WIRE AND J/B NO.2 (ENGINE COMPARTMENT LEFT)

### □ : CONNECTOR JOINING WIRE HARNESS AND WIRE HARNESS

CODE	SEE PAGE	JOINING WIRE HARNESS AND WIRE HARNESS (CONNECTOR LOCATION)
EA2	32	COWL WIRE AND ENGINE ROOM MAIN WIRE (FRONT SIDE OF RIGHT FENDER)
EA3	32	COWL WIRE AND ENGINE ROOM MAIN WIRE (INSIDE OF J/B NO.2)
IH1	34	INSTRUMENT PANEL WIRE AND COWL WIRE (J/B NO.1)
BQ1	38	COWL WIRE AND FLOOR NO.2 WIRE (LEFT KICK PANEL)

### ▽ : GROUND POINTS

CODE	SEE PAGE	GROUND POINTS LOCATION
EA	32	FRONT SIDE OF RIGHT FENDER
EB	32	FRONT SIDE OF LEFT FENDER
IE	34	LEFT KICK PANEL
IH	34	RIGHT KICK PANEL
BI	38	UNDER THE LEFT REAR PILLAR
BK	38	BACK PANEL RIGHT

### ○ : SPLICE POINTS

CODE	SEE PAGE	WIRE HARNESS WITH SPLICE POINTS	CODE	SEE PAGE	WIRE HARNESS WITH SPLICE POINTS
E 3	32	ENGINE ROOM MAIN WIRE	I 26	36	COWL WIRE
E 18			I 58		
I 4	36	COWL WIRE	I139	36	INSTRUMENT PANEL WIRE
I 7			I140		
I 8			B 53	38	FLOOR NO.2 WIRE
I 9			B 56		

C12 (B)



C14 (A)

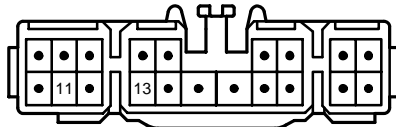

C16 BLACK

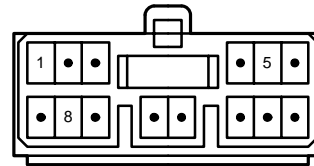

F 9 GRAY



F10 GRAY



H10

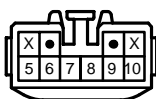

J 1

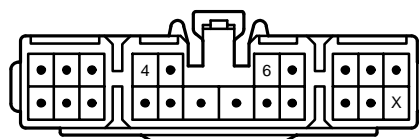

R13

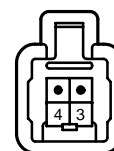

R15

