



**Technical Service  
Information Bulletin**

December 1, 2006

Title: **BRAKE PAD CLICKING NOISE**

Models: **'07 LS 460/460L**

REVISED  
BR005-06  
BRAKES

**TSIB REVISION NOTICE:**

- **July 19, 2007:** The Introduction has been updated. Applicable Vehicles has been updated. The Production Change Information table has been added. The Warranty Information table has been updated. Steps 2 – 4 of the Repair Procedure have been updated. PLEASE READ ENTIRE TSIB.

Previous versions of this TSIB should be discarded.

**Introduction** Some 2007 model year LS 460/460L customers may complain of a “clicking” noise from the front and rear brakes when traveling in reverse and applying light brake pressure or when shifting from drive to reverse.

- LS 460/460L equipped w/18” standard wheel — The front and rear brake pad backing plates have been modified. Install new front and rear brake pads and apply grease to reduce this condition.
- LS 460L equipped w/19” Touring Package wheel option (high friction brake pad) — No changes have been made to the brake pads. Apply grease to reduce this condition.

**Applicable Vehicles** • **2007** model year **LS 460/460L** vehicles produced **BEFORE** the Production Change Effective VINs shown in this TSIB.

**Warranty Information**

OP CODE	DESCRIPTION	MODEL	TIME	OPF	T1	T2
473301	R & R Front Disc Brake Pad and/or Disc Brake Pad Shim (Both Sides)	LS 460/460L w/18” Standard Wheel	0.9	04465–50260	91	43
473311	R & R Rear Disc Brake Pad and/or Disc Brake Pad Shim (Both Sides)		1.0	04466–50130		
473301	R & R Front Disc Brake Pad and/or Disc Brake Pad Shim (Both Sides)	LS 460L w/19” Touring Package Wheel Option	0.9	04465–0W110		
473311	R & R Rear Disc Brake Pad and/or Disc Brake Pad Shim (Both Sides)		1.0	04466–0W010		

**Applicable Warranty\*:**

**This repair is covered under the Lexus Comprehensive Warranty. This warranty is in effect for 48 months or 50,000 miles, whichever occurs first, from the vehicle’s in-service date.**

\* Warranty application is limited to correction of a problem based upon a customer’s specific complaint.



Production  
Change  
Information

MODEL	PRODUCTION CHANGE EFFECTIVE VIN
LS 460	JTHBL46F#75018579
LS 460L	JTHGL46F#75005551

Parts  
Information**LS 460/460L equipped w/18” Standard Wheel:**

PREVIOUS PART NUMBER	CURRENT PART NUMBER	PART NAME	QTY
04465–50260	Same	Front Brake Pad Kit	1
04466–50130	Same	Rear Brake Pad Kit	1
N/A	08887–80609	Disc Brake Caliper Grease (50 g Tube)	1

**NOTE:**

One 50 g tube of the Disc Brake Caliper Grease should be enough for 20 vehicles depending on application.

**LS 460L equipped w/19” Touring Package Wheel Option:**

PREVIOUS PART NUMBER	CURRENT PART NUMBER	PART NAME	QTY
N/A	08887–80609	Disc Brake Caliper Grease (50 g Tube)	1

**NOTE:**

One 50 g tube of the Disc Brake Caliper Grease should be enough for 20 vehicles depending on application.

Repair  
Procedure

1. Drive the vehicle to confirm the customer’s complaint.

The “clicking” noise is heard while traveling in reverse and applying light brake pressure ON and OFF the pedal or when changing vehicle direction.

2. **For LS 460/460L equipped w/18” Standard Wheel:**

Remove and replace the front and rear brake pads.

Refer to the Technical Information System (TIS), 2007 model year LS 460 Repair Manual:

- Brake – Brake (front) – “Brake: Front Brake: Removal”
- Brake – Brake (rear) – “Brake: Rear Brake: Removal”

**For LS 460L equipped w/19” Touring Package Wheel Option:**

Remove the front and rear brake pads and clean ONLY.

**Repair Procedure**  
(Continued)

3. **For all LS 460/460L vehicles:** After cleaning the shims and calipers, apply a light film of the Disc Brake Caliper Grease to the front brake pads, calipers, and shims in the areas shown in the illustration using your fingertip.

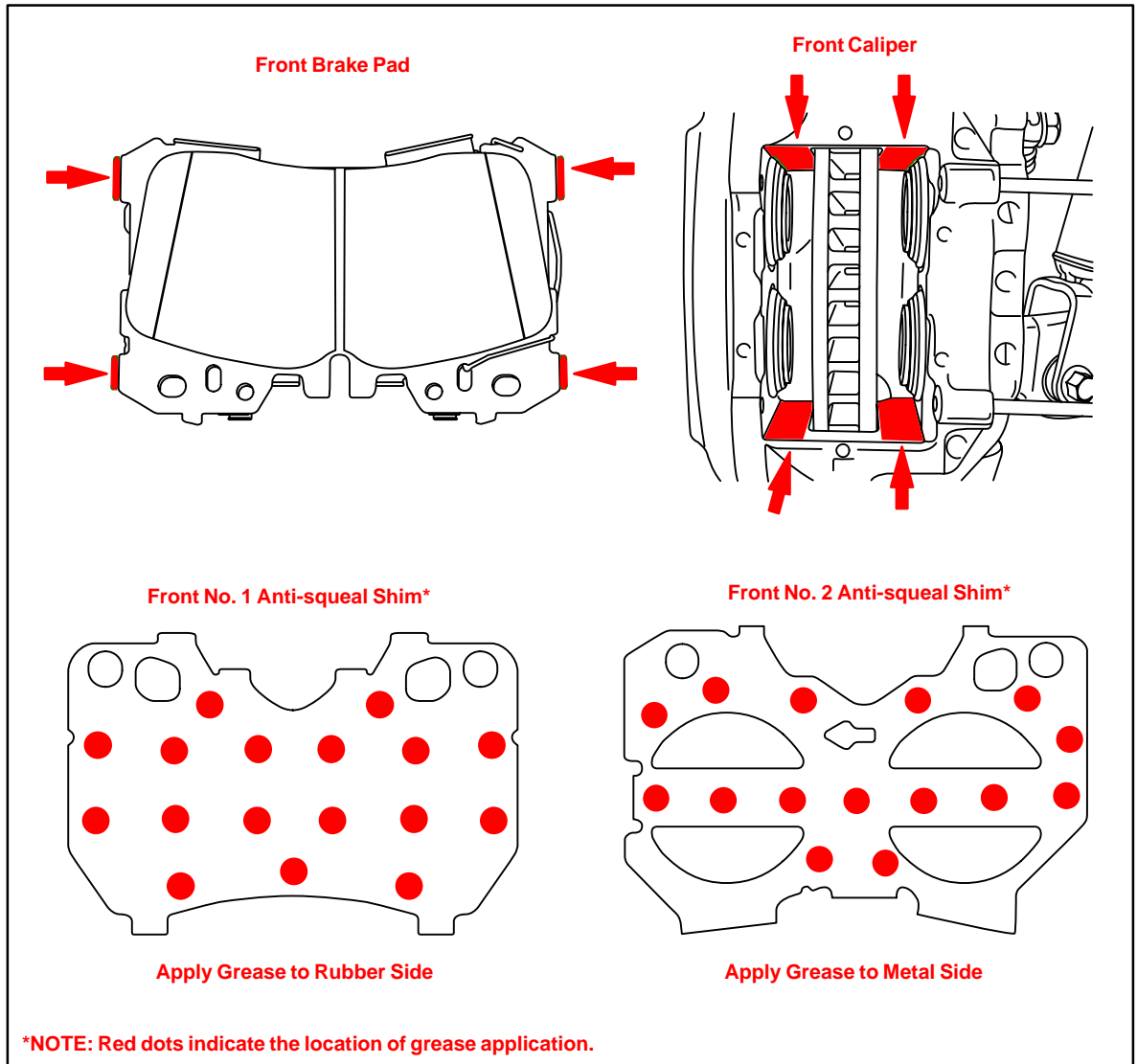

**Repair  
Procedure**  
(Continued)

4. **For all LS 460/460L vehicles:** After cleaning the shims and calipers, apply a light film of the Disc Brake Caliper Grease to the rear brake pads and calipers in the areas shown in the illustration using your fingertip.

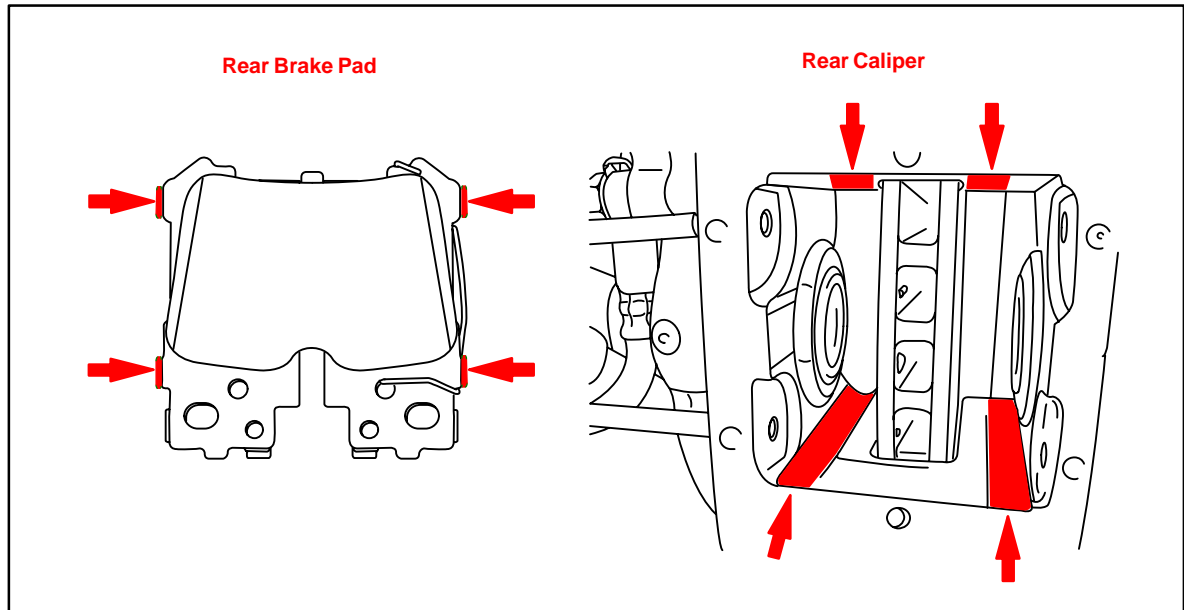

5. Reinstall the front and rear brake pads into the caliper assemblies.  
Refer to the Technical Information System (TIS), 2007 model year LS 460 Repair Manual:
- *Brake – Brake (front) – “Brake: Front Brake: Installation”*
  - *Brake – Brake (rear) – “Brake: Rear Brake: Installation”*
6. Road test the vehicle to confirm the front and rear brake “clicking” noise has been reduced.