

Headlight

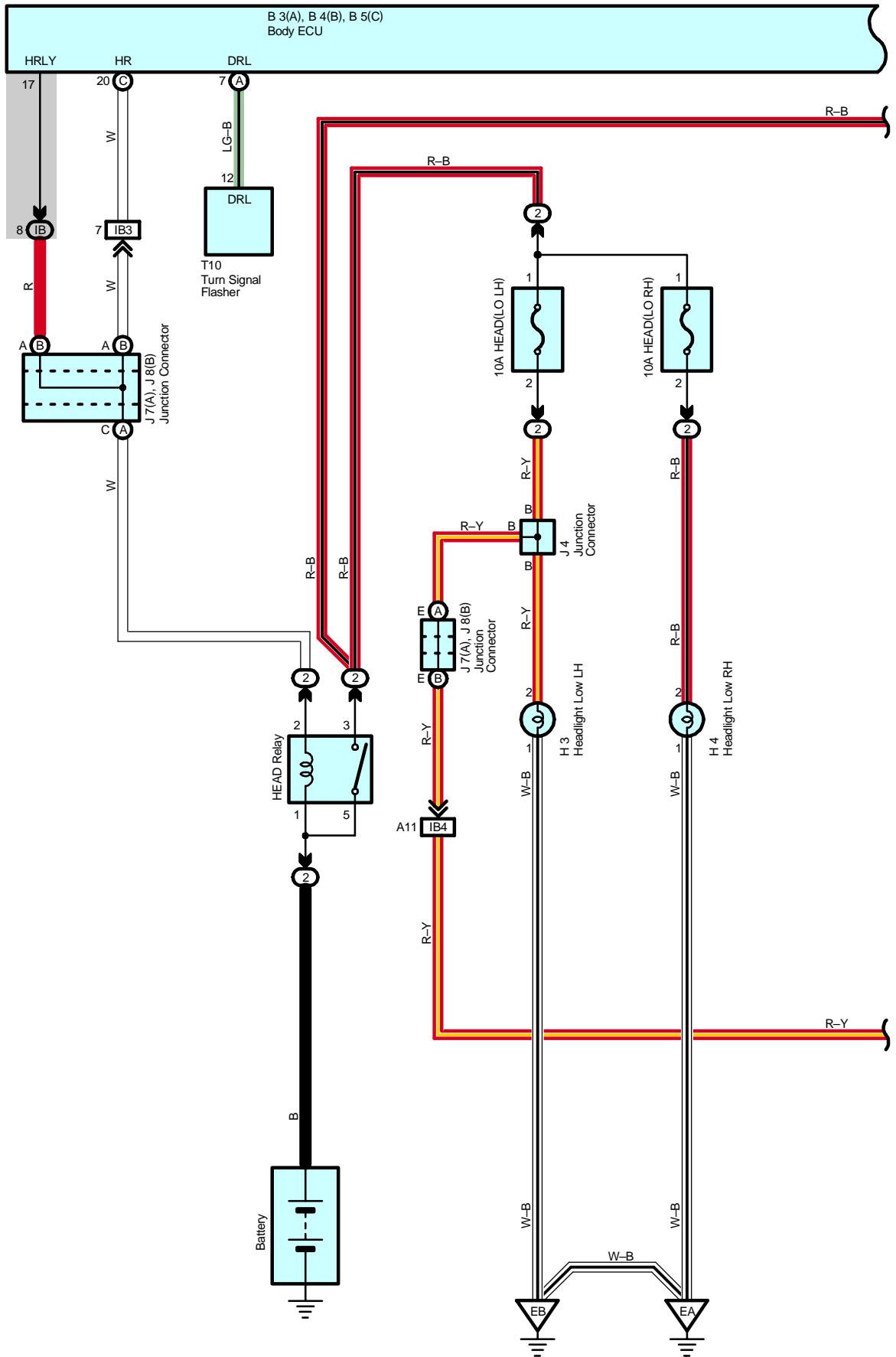

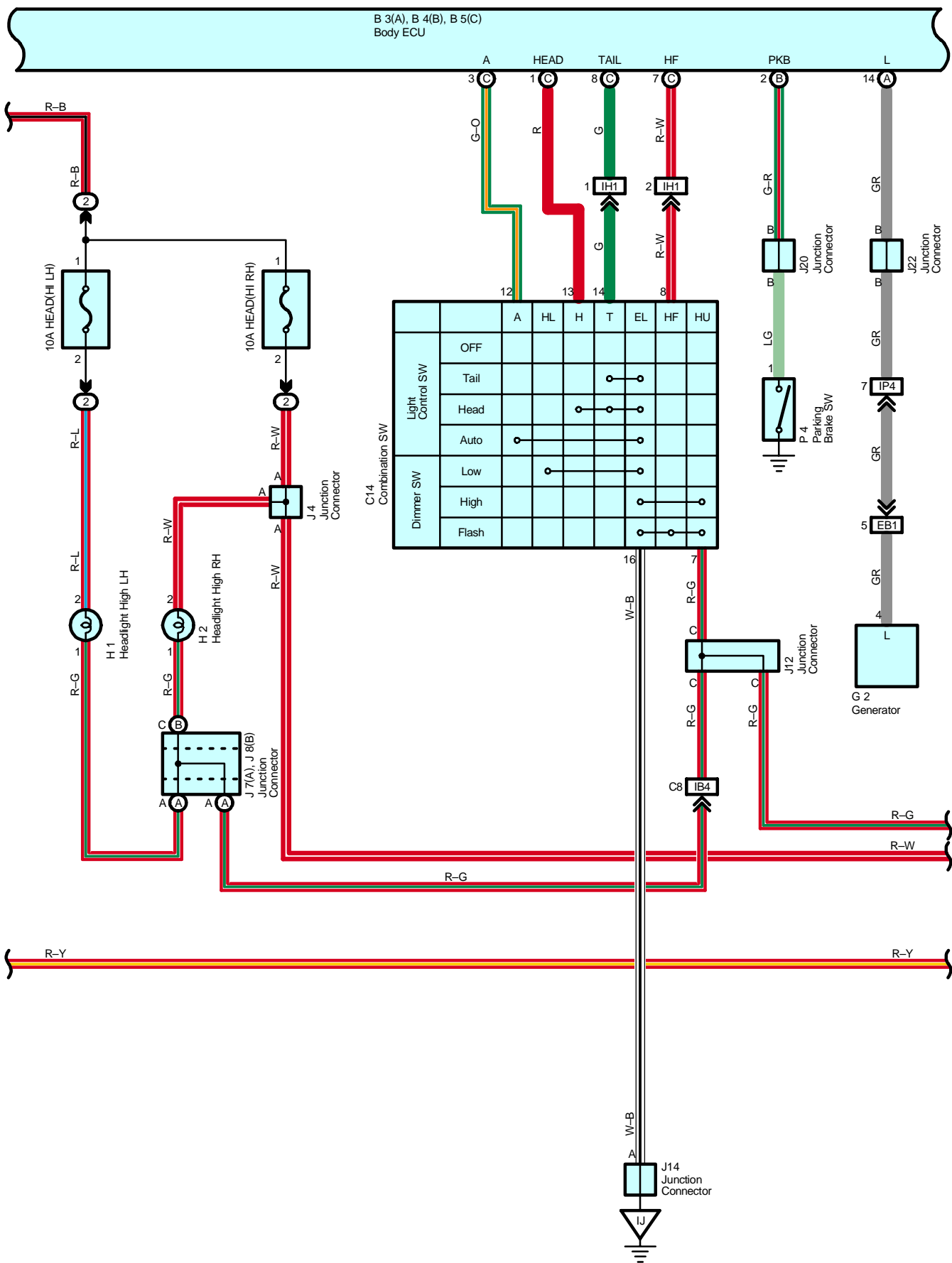

Headlight

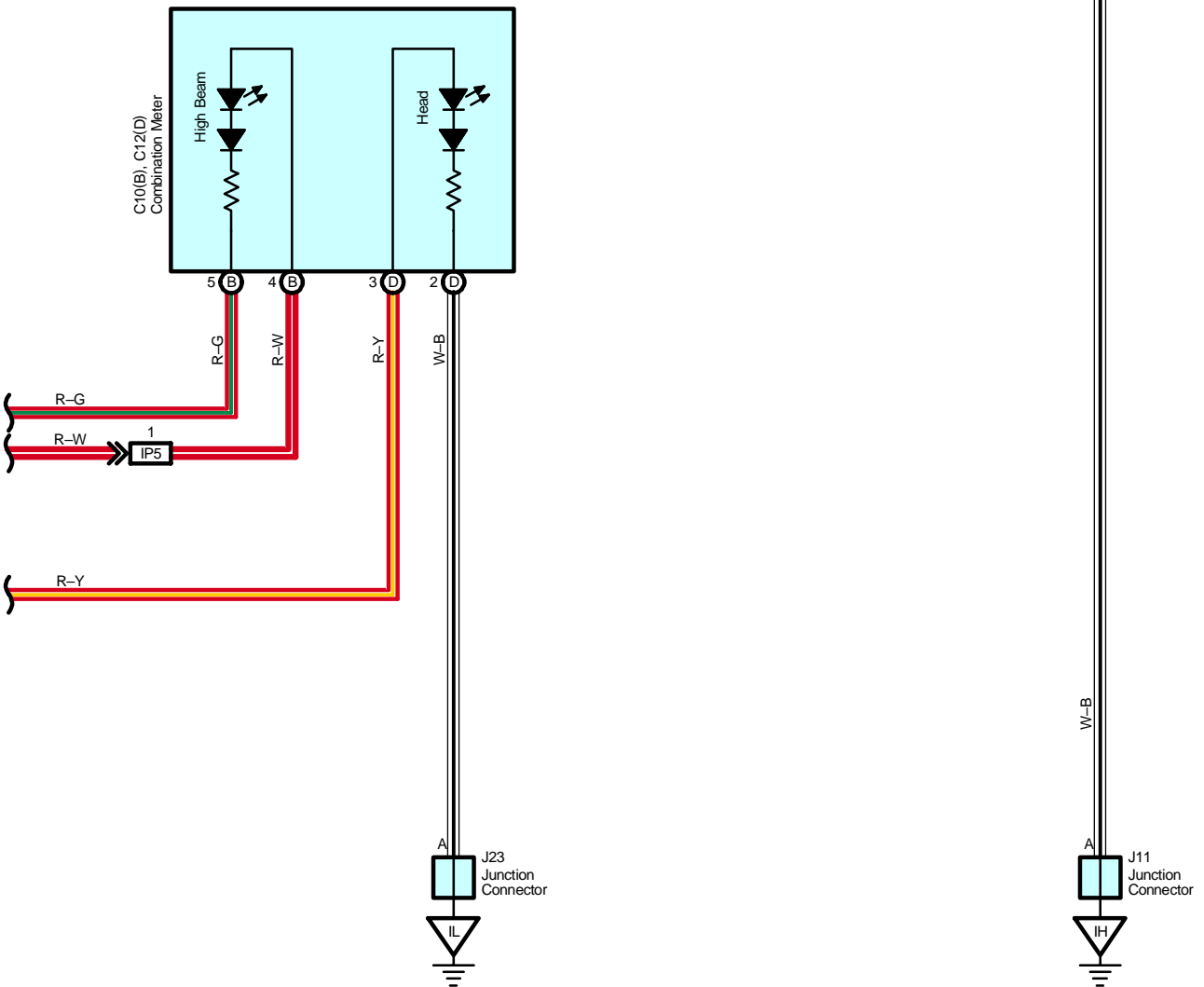
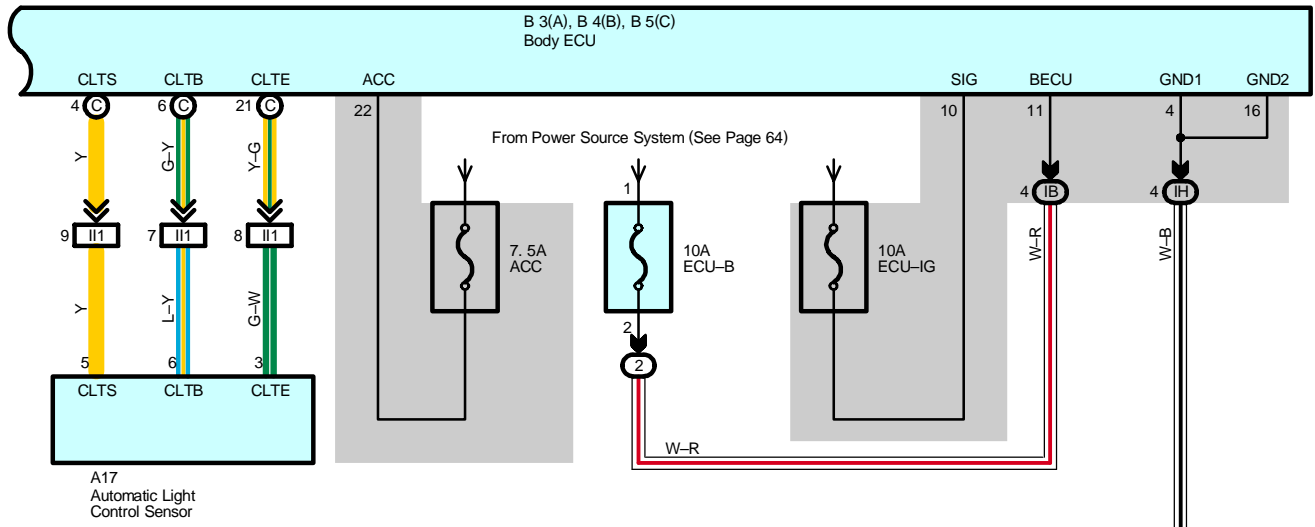

System Outline

* This system is designed to automatically activate the turn signal lights during the daytime to keep the car highly visible to other vehicles. This system is controlled by the body ECU.

This system makes use of the turn signal lights as daytime running lights.

For this reason, when the turn signal lights are operated, the daytime running lights function is interrupted momentarily, which, however, will be brought back into operation as soon as the interposed operation is over.

* This system is enabled when the conditions given below are met.

- A) Ignition switch ON condition
- B) Turn signal light switch OFF condition
- C) Hazard light switch OFF condition
- D) Light control switch OFF condition
- E) Parking brake switch OFF condition (Parking brake out of operating condition)**

** : This system does not become active when the parking brake switch is ON. However, once the OFF signal of the parking brake switch is input into the body ECU, this system will become active thereafter, regardless of whether the parking brake switch is ON or OFF.

Service Hints

Body ECU

- 4, 16-Ground : Always continuity
- 11-Ground : Always approx. 12 volts
- 10-Ground : Approx. 12 volts with the ignition SW at ON position
- 22-Ground : Approx. 12 volts with the ignition SW at ON or ACC position

: Parts Location

Code	See Page	Code	See Page	Code	See Page
A17	38	H1	36	J12	40
B3	A 38	H2	36	J14	40
B4	B 38	H3	36	J20	40
B5	C 38	H4	36	J22	40
C10	B 38	J4	37	J23	40
C12	D 38	J7	A 40	P4	40
C14	38	J8	B 40	T10	41
G2	36	J11	40		

: Relay Blocks

Code	See Page	Relay Blocks (Relay Block Location)
2	22	Engine Room R/B (Engine Compartment Left)

: Junction Block and Wire Harness Connector

Code	See Page	Junction Block and Wire Harness (Connector Location)
IB	26	Engine Room Main Wire and Driver Side J/B (Lower Finish Panel)
IH	27	Instrument Panel Wire and Driver Side J/B (Lower Finish Panel)

: Connector Joining Wire Harness and Wire Harness

Code	See Page	Joining Wire Harness and Wire Harness (Connector Location)
EB1	48	Engine No.2 Wire and Engine Room Main Wire (Near the Engine Room R/B)
IB3	50	Instrument Panel Wire and Engine Room Main Wire (Left Kick Panel)
IB4		
IH1	52	Instrument Panel Wire and Instrument Panel Wire (Near the J/B No.1)
II1	52	Instrument Panel No.3 Wire and Instrument Panel Wire (Near the Combination Meter)
IP4	54	Instrument Panel Wire and Engine Room Main Wire (Right Kick Panel)
IP5		

Headlight



: Ground Points

Code	See Page	Ground Points Location
EA	48	Front Right Fender
EB	48	Front Left Fender
IH	50	Left Kick Panel
IJ	50	Near the Right Side of Steering Column
IL	50	Right Kick Panel

