



**Technical Service
Information Bulletin**

August 2, 2006

Title:

3RD - 4TH GEAR SHIFT FLARE

Models:

'07 ES 350

TSIB

REVISED

TC004-06

TRANSMISSION & CLUTCH

TSIB REVISION NOTICE:

- August 7, 2006: The OFP has been updated in Warranty Information. Applicable Warranty has been changed from Comprehensive to Powertrain. Previous versions of this TSIB should be discarded.

Introduction

Some customers may experience a sharp increase in RPM between the 3rd to 4th gear shift point during the first ten minutes of operation after a cold start. A revised transmission valve body has been developed to address this concern.

NOTE:

This TSIB **ONLY** applies to vehicles that have been confirmed to have the customer concerns listed above.

Applicable Vehicles

- 2007 model year **ES 350** vehicles.

Parts Information

PREVIOUS PART NUMBER	CURRENT PART NUMBER	PART NAME	QTY
35410-33170	Same	Body Assembly, Transmission Valve	1
90301-27010	Same	O-ring, Oil Strainer	1
35168-33080	Same	Gasket, Transmission Oil Pan	1
08886-02305	Same	ATF WS	3.4 qts (3.2 liters, 2.8 Imp. qts)
90430-12008	Same	Gasket, Overflow Plug	1

Required Tools & Material

TOOLS & MATERIAL	QUANTITY
Toyota Genuine Adhesive 1344, Three Bond 1344, or equivalent	As Needed

Warranty Information

OP CODE	DESCRIPTION	TIME	OFP	T1	T2
369251	R & R Valve Body Assembly	2.2	35410-33170	91	99



Applicable Warranty*:

This repair is covered under the Lexus Powertrain Warranty. This warranty is in effect for 72 months or 70,000 miles, whichever occurs first, from the vehicle's in-service date.

* Warranty application is limited to correction of a problem based upon a customer's specific complaint.



Required SSTs

ITEM NO.	SPECIAL SERVICE TOOLS (SSTs)	PART NUMBER	QTY	DRW**
1	<p>Lexus Diagnostic Tester Kit*</p> <p>NOTE:</p> <ul style="list-style-type: none"> All components from this kit/set are required. 12 Megabyte Diagnostic Tester Program Card (P/N 01002593–005) with version 13.3a Software (or later) is required. 	LEX220036	1	8
2	<p>CAN Interface Module Kit*</p> <p>NOTE:</p> <ul style="list-style-type: none"> All components from this kit/set are required. 	01002744	1	8

* Essential SSTs.

** Refers to drawer number in SST Storage System.

NOTE:
Additional Diagnostic Tester Kits, CAN Interface Modules, Program Cards, or other SSTs may be ordered by calling SPX/OTC at 1-800-933-8335.

Repair Procedure

1. Allow the vehicle to cold soak for a minimum of 4 hours.
2. Connect the Diagnostic Tester to DLC3.
3. Turn the engine switch ON.
4. Turn the Diagnostic Tester ON.
5. Enter the following menus on the tester:
 DIAGNOSIS / OBD–MOBD / ECT / DATA LIST.
6. Start the engine.
7. Monitor SHIFT position and ENGINE SPD while driving the vehicle with light throttle application (under 40% throttle angle).
8. If shift flare is experienced when shifting from 3rd to 4th gear, remove and replace the transmission valve body.
 - A. Remove the automatic transaxle oil pan sub–assembly.
 - a. Remove the 18 bolts and oil pan from the transaxle.

NOTE:
Some fluid will remain in the oil pan. Remove all the pan bolts, and carefully remove the oil pan assembly.

- b. Remove the gasket from the oil pan.

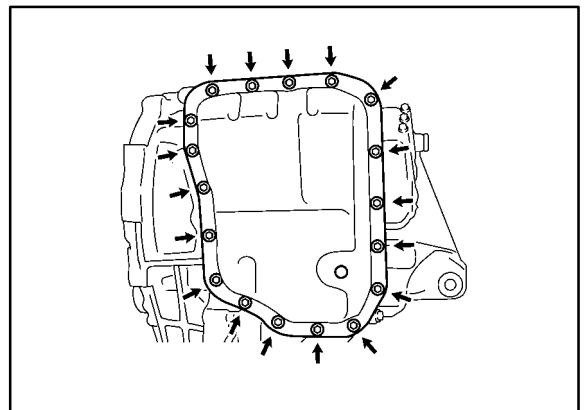

**Repair
Procedure**
(Continued)

- B. Remove the valve body oil strainer assembly.
- a. Remove the 2 bolts and oil strainer from the valve body.

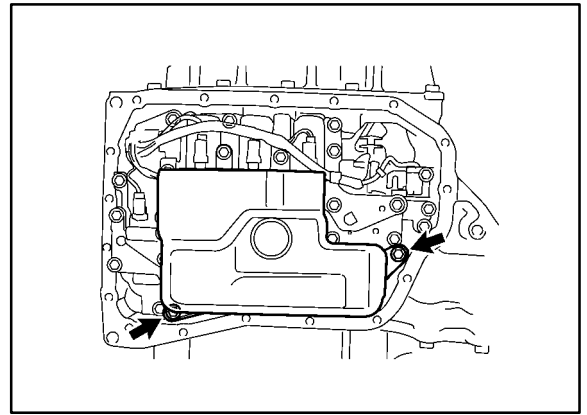

- b. Remove the O-ring from the oil strainer.

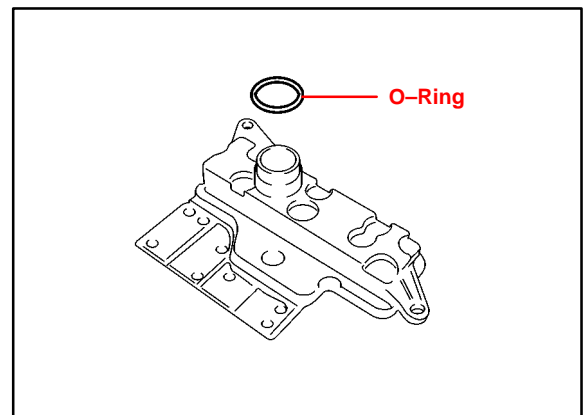

- C. Remove the transmission valve body assembly.
Remove the 11 bolts and valve body from the transaxle.

NOTE:

When removing the transmission valve body assembly, be careful NOT to allow the transmission revolution sensor and the transaxle case to interfere with each other.

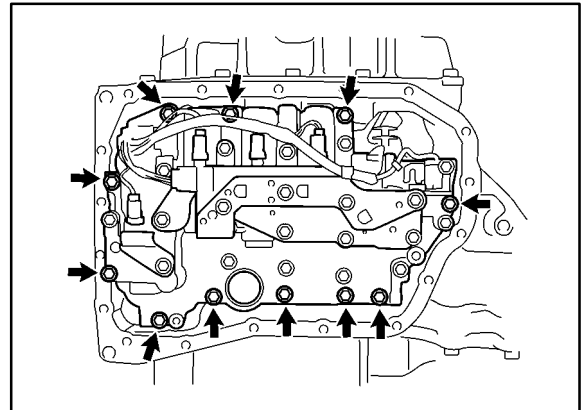

- D. Remove the manual valve from the valve body.
- E. Coat the manual valve with ATF and install it into the NEW valve body.
- F. Install the transmission valve body assembly.
- a. Coat the O-ring of the transmission wire with ATF.

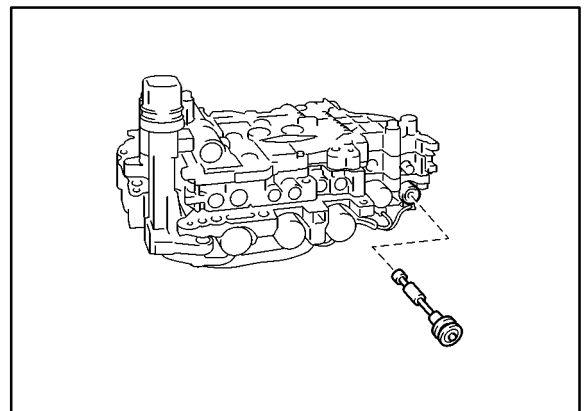

**Repair
Procedure**
(Continued)

- b. Confirm that the manual valve lever is positioned as shown in the illustration and install the valve body assembly to the transaxle case with the 11 bolts.

Torque: 11 N•m
(112 kgf•cm, 8 ft•lbf)

Bolt length:

Bolt A: 25 mm (0.98 in.)
Bolt B: 30 mm (1.18 in.)
Bolt C: 35 mm (1.38 in.)
Bolt D: 45 mm (1.77 in.)
Bolt E: 55 mm (2.17 in.)

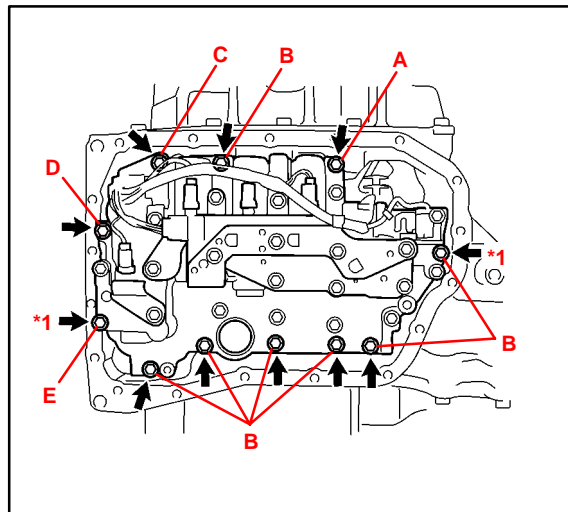

NOTE:

- First, temporarily tighten the bolts marked by (*1) in the illustration because they are positioning bolts.
- When installing the transmission valve body assembly, be careful NOT to allow the transmission revolution sensor and transaxle case to interfere with each other.
- Be sure to insert the pin of the manual valve lever into the groove on the end of the manual valve.

- G. Install the valve body oil strainer assembly.
- a. Coat a NEW O-ring with ATF and install it to the oil strainer.

NOTE:

Ensure that the O-ring is NOT twisted or pinched.

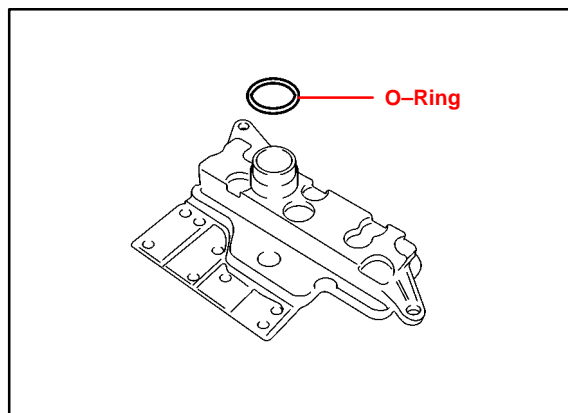

**Repair
Procedure**
(Continued)

- b. Install the oil strainer to the valve body with the 2 bolts.

**Torque: 11 N•m
(112 kgf•cm, 8 ft•lbf)**

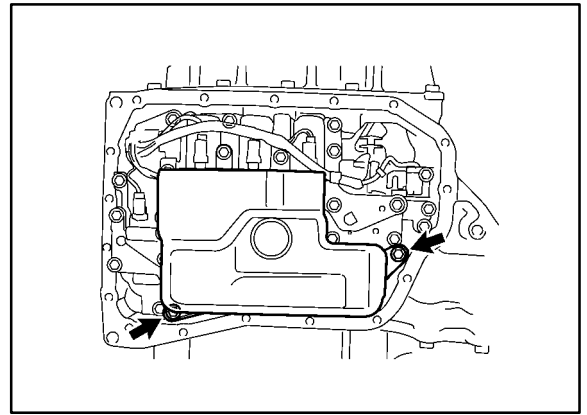

- H. Install the automatic transaxle oil pan sub-assembly.

- a. Confirm the position of the 2 magnets in the oil pan.
b. Install a NEW gasket to the oil pan.
c. Apply adhesive to the 18 bolts.

**Adhesive:
Toyota Genuine Adhesive 1344,
Three Bond 1344, or equivalent**

- d. Install the oil pan to the automatic transaxle with the 18 bolts.

**Torque: 7.5 N•m
(76 kgf•cm, 66 in•lbf)**

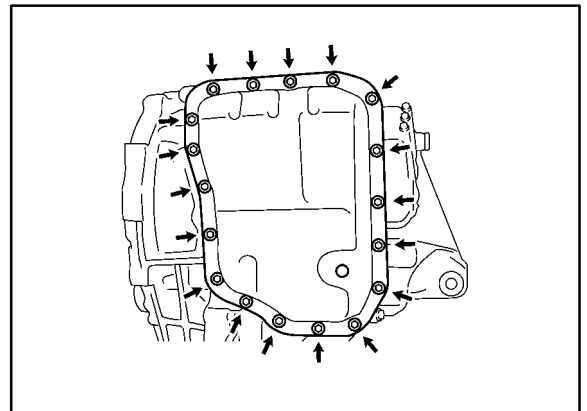
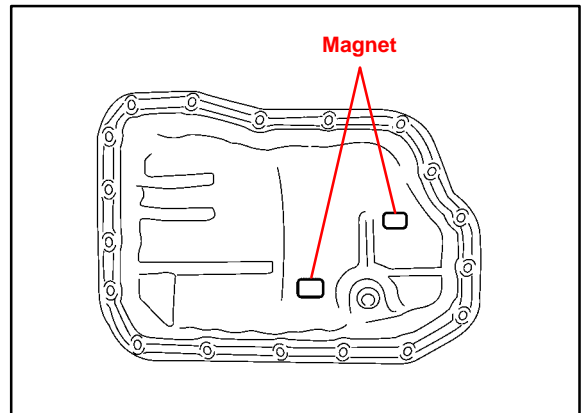

NOTE:

- In order to ensure proper sealing of the transmission oil pan bolts, apply adhesive to the bolts and install them within 10 minutes of adhesive application.
- Completely remove any oil or grease from the contact surface of the transaxle case and oil pan sub-assembly with the gasket before installation.

- I. Fill transaxle with automatic transaxle fluid.

Automatic Transaxle Fluid: Genuine ATF WS Transmission Fluid

Refer to the Technical Information System (TIS), 2007 model year ES 350 Repair Manual: *U660E Automatic Transaxle: Automatic Transaxle Assembly: Installation.*

**Repair
Procedure**
(Continued)

9. After replacement of the transmission valve body:
 - A. Connect the Diagnostic Tester to DLC3.
 - B. Turn the engine switch ON and turn the Diagnostic Tester ON.
 - C. Enter the following menus on the tester:
DIAGNOSIS / OBD–MOBD / ECT / AT CODE UTILITY.
 - D. Select “AT CODE RESET” on the tester.
 - E. Press “ENTER.”
10. Perform a road test to allow the TCM to learn.

NOTE:

Perform the following procedures while strictly observing all traffic laws and speed limits.

- A. Warm up the engine.
- B. From a standstill, achieve the highest possible speed with the accelerator pedal opened 15% or less. Keep the accelerator pedal angle steady while driving the vehicle.
- C. Repeat the previous step until shift shock no longer occurs.
- D. From a standstill, achieve the highest possible speed with the accelerator pedal opened 25% or more. Keep the accelerator pedal angle steady while driving the vehicle.
- E. Repeat the previous step until shift shock no longer occurs.

NOTE:

If valve body replacement does NOT correct the condition, continue diagnosis following the Repair Manual Problem Symptoms Table. If necessary, contact Technical Assistance for further support.