

Exhaust Drone at Takeoff or Under Light Acceleration

Service Category Engine/Hybrid System

Section Intake/Exhaust

Market USA

Lexus Supports
ASE Certification 

Applicability

YEAR(S)	MODEL(S)	ADDITIONAL INFORMATION
2016 - 2018	RX350	VDS(s): BZMCA, ZZMCA

REVISION NOTICE

March 12, 2018 Rev1:

- The Parts Information section has been updated.

Any previous printed versions of this bulletin should be discarded.

Introduction

Some 2016 – 2018 model year RX 350 vehicles may exhibit a droning noise from the exhaust system at takeoff or under light acceleration. Countermeasure parts are available to reduce the droning noise. Follow the Repair Procedure in this bulletin to address this condition.

Warranty Information

OP CODE	DESCRIPTION	TIME	OFF	T1	T2
EG1708	R & R Exhaust Center Pipe Assembly	0.5	17420-0P250 17420-31570	91	99

APPLICABLE WARRANTY

- This repair is covered under the Lexus Federal Long-Term Emission Warranty. This warranty is in effect for 96 months or 80,000 miles, whichever occurs first, from the vehicle's in-service date.
- Warranty application is limited to occurrence of the specified condition described in this bulletin.

Exhaust Drone at Takeoff or Under Light Acceleration

Parts Information

PART NUMBER		PART NAME	QTY
PREVIOUS	NEW		
17420-0P250 17420-31570	17420-0P540	Pipe Assy, Exhaust, Center	1
17451-0D140		Gasket, Exhaust Pipe	1
90917-A6001		Gasket, Exhaust Pipe, No. 2.	1

Required Tools & Equipment

REQUIRED TOOLS & MATERIAL	QUANTITY
Vernier Caliper Gauge	1

Repair Procedure

1. Confirm the condition exists.
 Does the vehicle exhibit a droning noise from the exhaust system?
 - **YES** — Continue to step 2.
 - **NO** — This bulletin does NOT apply. Continue diagnosis using the applicable Repair Manual.

Exhaust Drone at Takeoff or Under Light Acceleration

Repair Procedure (continued)

2. Confirm if the vehicle has the NEW center exhaust pipe. The NEW part can be identified by the addition of a bracket and damper attached to the center exhaust pipe as shown.

Does the vehicle have the NEW center exhaust pipe?

- **YES** — This bulletin does NOT apply. Continue diagnosis using the applicable Repair Manual.
- **NO** — Continue to step 3.

Figure 1.

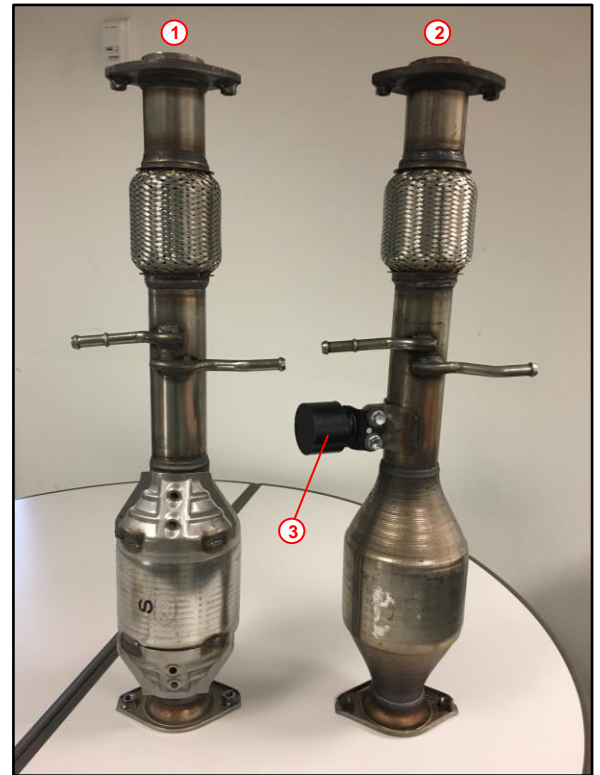

1	Old Part
2	New Part
3	Bracket and Damper

3. Remove the center exhaust pipe assembly.

CAUTION

To prevent burns, do NOT touch the engine, exhaust pipe, or other high-temperature components while the engine is hot.

- A. Remove the two bolts and two compression springs to disconnect the center exhaust pipe assembly from the front No. 3 exhaust pipe sub-assembly.
- B. Remove the center exhaust pipe assembly from the two exhaust pipe supports.
- C. Remove the exhaust pipe gasket from the front No. 3 exhaust pipe sub-assembly.

Figure 2.

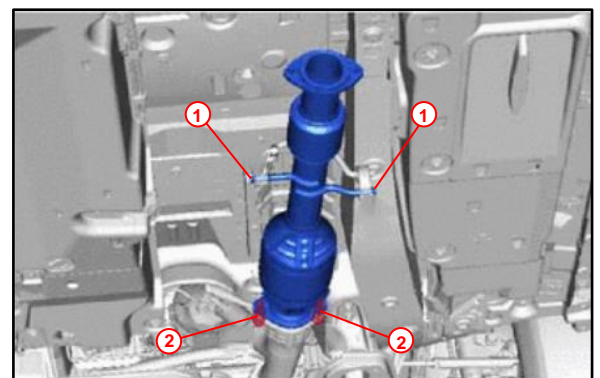

1	Compression Spring
2	Bolt

Exhaust Drone at Takeoff or Under Light Acceleration

Repair Procedure (continued)

4. Install the NEW center exhaust pipe assembly.

NOTICE

The flexible joint of the center exhaust pipe assembly may become deformed if subjected to extreme force.

- Do NOT hold the center exhaust pipe assembly by the flexible joint end.
- Do NOT bend the flexible joint excessively.

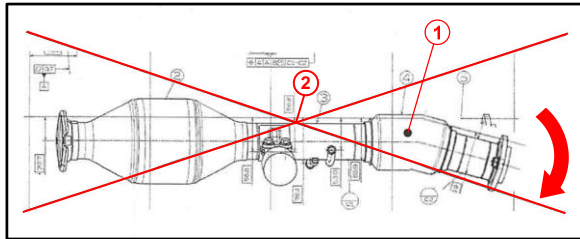

1	Flexible Joint
2	Do Not Bend

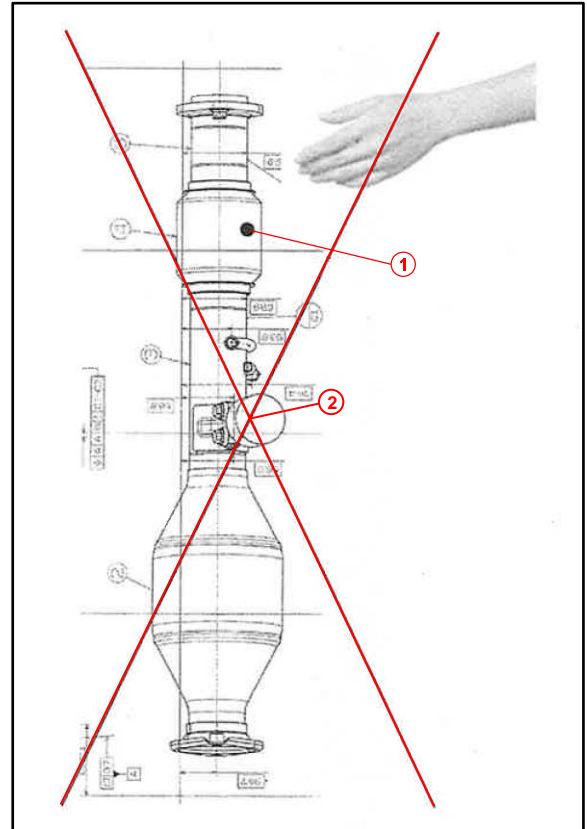

1	Flexible Joint
2	Do Not Bend

- A. Using a Vernier caliper gauge, measure the free length of the two compression springs.

STANDARD LENGTH	MINIMUM FREE LENGTH
43.0 mm (1.69 in.)	41.5 mm (1.63 in.)

If the free length is less than the minimum, replace the compression spring.

Figure 3.

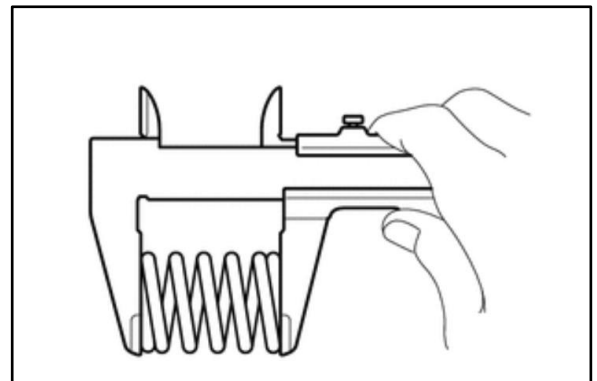

- B. Temporarily install a NEW exhaust pipe gasket onto the front No. 3 exhaust pipe sub-assembly.

Exhaust Drone at Takeoff or Under Light Acceleration

Repair Procedure (continued)

- C. Using a plastic hammer and wooden block, tap in the exhaust pipe gasket until its surface is flush with the front No. 3 exhaust pipe sub-assembly.

NOTICE

Be careful with the installation direction of the exhaust pipe gasket.

- Do NOT reuse the exhaust pipe gasket.
- Do NOT damage the exhaust pipe gasket.
- Do NOT push in the exhaust pipe gasket by using the exhaust pipes when connecting them.

Figure 4.

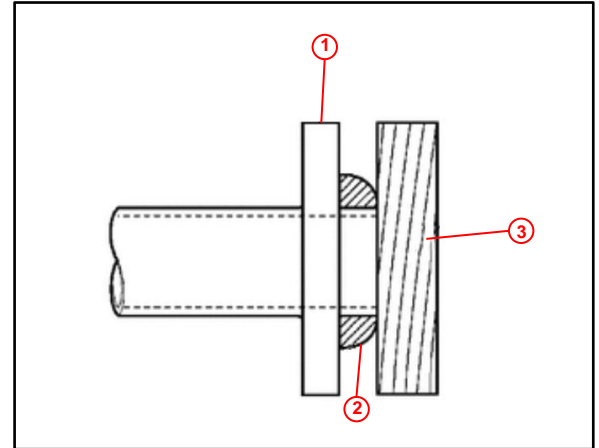

1	Front No. 3 Exhaust Pipe Sub-assembly
2	Exhaust Pipe Gasket
3	Wooden Block

- D. Connect the center exhaust pipe assembly to the two exhaust pipe supports.

- E. Install the center exhaust pipe assembly to the front No. 3 exhaust pipe sub-assembly with the two bolts and two compression springs.

Torque: 43 N*m (438 kgf*cm, 32 ft*lbf)

HINT

AFTER installation, check that the space between the flanges of the center exhaust pipe assembly and the front No. 3 exhaust pipe sub-assembly is consistent front-to-rear and left-to-right.

Figure 5.

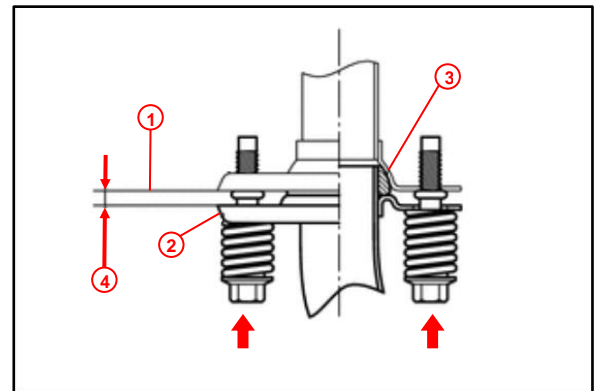

1	Center Exhaust Pipe Assembly
2	Front No. 3 Exhaust Pipe Sub-assembly
3	Exhaust Pipe Gasket
4	Space Between Flanges: 8.5 mm (0.335 in.)

5. Confirm the droning noise is reduced.