

# POWER SOURCE

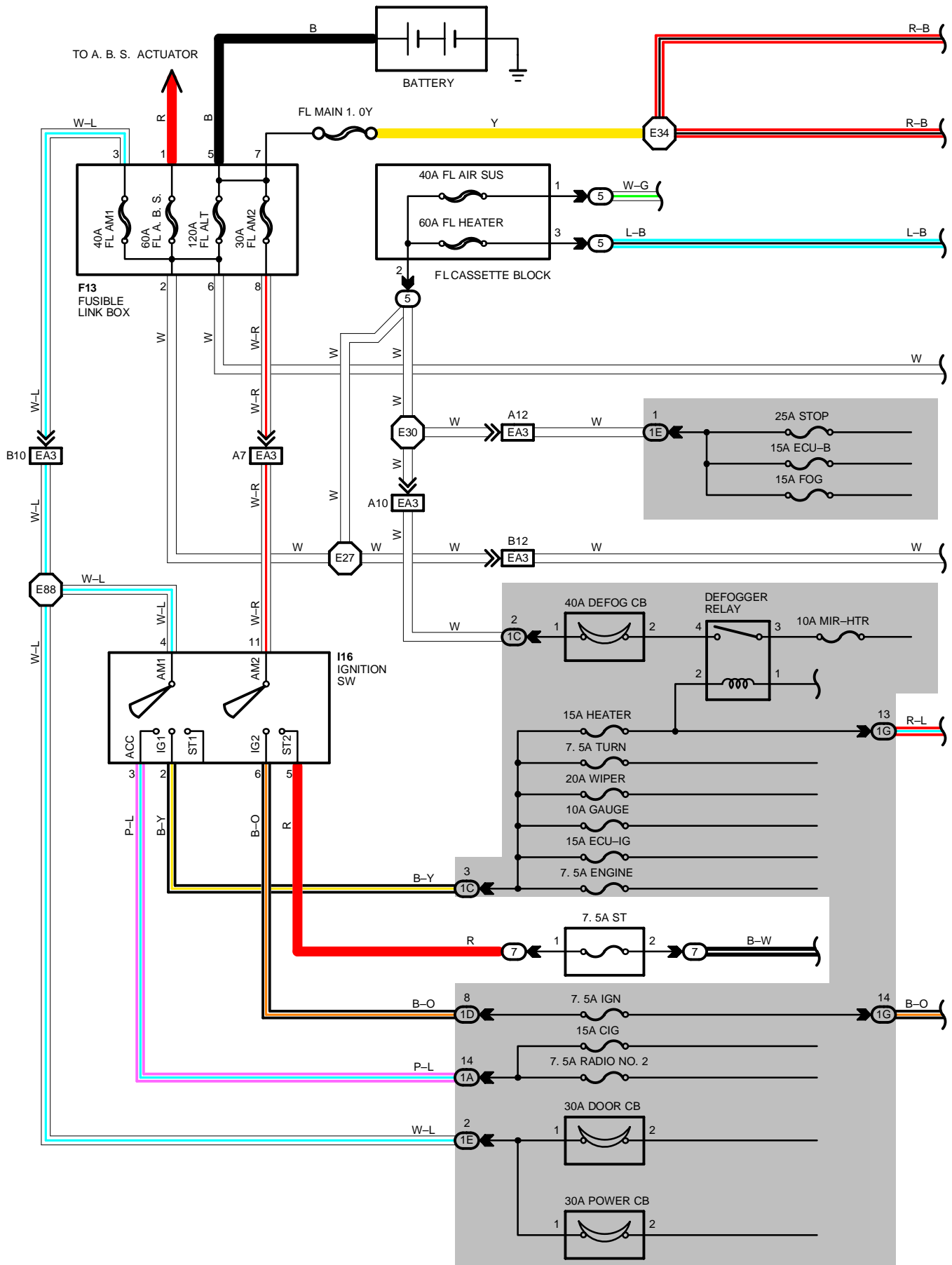

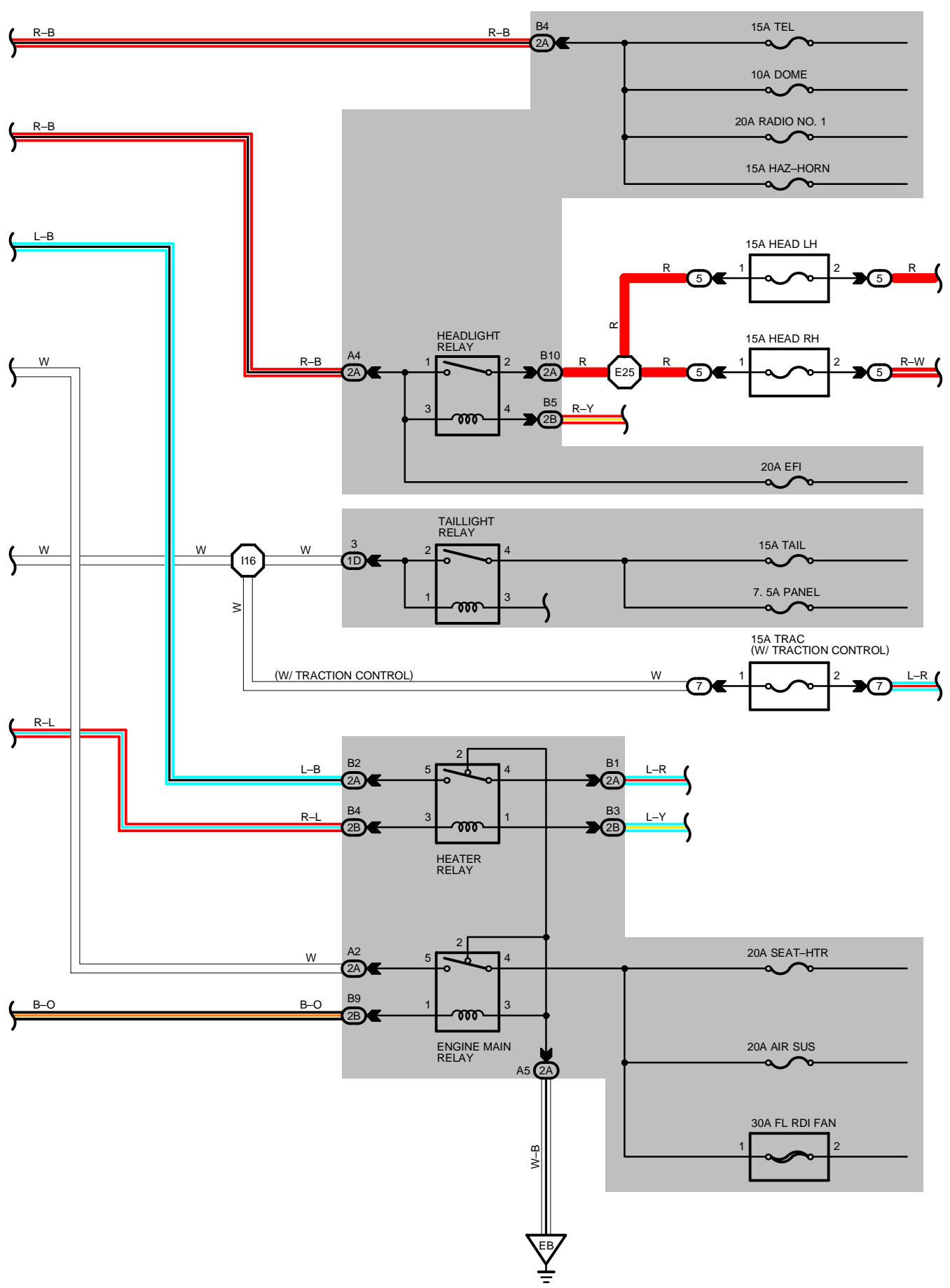

# POWER SOURCE

## SERVICE HINTS

### HEADLIGHT RELAY

1-2 : CLOSED WITH LIGHT CONTROL SW AT **HEAD** POSITION OR DIMMER SW AT **FLASH** POSITION

### TAILLIGHT RELAY

4-2 : CLOSED WITH LIGHT CONTROL SW AT **TAIL** OR **HEAD** POSITION

### ENGINE MAIN RELAY

4-5 : CLOSED WITH IGNITION KEY AT **ON** OR **ST** POSITION

### 116 IGNITION SW

4-3 : CLOSED WITH IGNITION KEY AT **ACC** OR **ON** POSITION

4-2 : CLOSED WITH IGNITION KEY AT **ON** OR **ST** POSITION

11-6 : CLOSED WITH IGNITION KEY AT **ON** OR **ST** POSITION

11-5 : CLOSED WITH IGNITION KEY AT **ST** POSITION

## ○ : PARTS LOCATION

CODE	SEE PAGE	CODE	SEE PAGE	CODE	SEE PAGE
F13	24	I16	26		

## ○ : RELAY BLOCKS

CODE	SEE PAGE	RELAY BLOCKS (RELAY BLOCK LOCATION)
5	20	R/B NO.5 (NEAR THE J/B NO.2)
7	18	R/B NO.7 (RIGHT SIDE OF J/B NO.1)

## ○ : JUNCTION BLOCK AND WIRE HARNESS CONNECTOR

CODE	SEE PAGE	JUNCTION BLOCK AND WIRE HARNESS (CONNECTOR LOCATION)
1A	18	COWL WIRE AND J/B NO.1 (LEFT SIDE OF STEERING COLUMN TUBE)
1C		
1D		
1E		
1G		
2A	20	ENGINE ROOM MAIN WIRE AND J/B NO.2 (ENGINE COMPARTMENT LEFT)
2B	20	COWL WIRE AND J/B NO.2 (ENGINE COMPARTMENT LEFT)

## □ : CONNECTOR JOINING WIRE HARNESS AND WIRE HARNESS

CODE	SEE PAGE	JOINING WIRE HARNESS AND WIRE HARNESS (CONNECTOR LOCATION)
EA3	32	COWL WIRE AND ENGINE ROOM MAIN WIRE (INSIDE OF J/B NO.2)

## ▽ : GROUND POINTS

CODE	SEE PAGE	GROUND POINTS LOCATION
EB	32	FRONT SIDE OF LEFT FENDER

## ○ : SPLICE POINTS

CODE	SEE PAGE	WIRE HARNESS WITH SPLICE POINTS	CODE	SEE PAGE	WIRE HARNESS WITH SPLICE POINTS
E 25	32	ENGINE ROOM MAIN WIRE	E 34	32	ENGINE ROOM MAIN WIRE
E 27			E 88	32	COWL WIRE
E 30			I 16	36	

