

# Headlight with Daytime Running Light

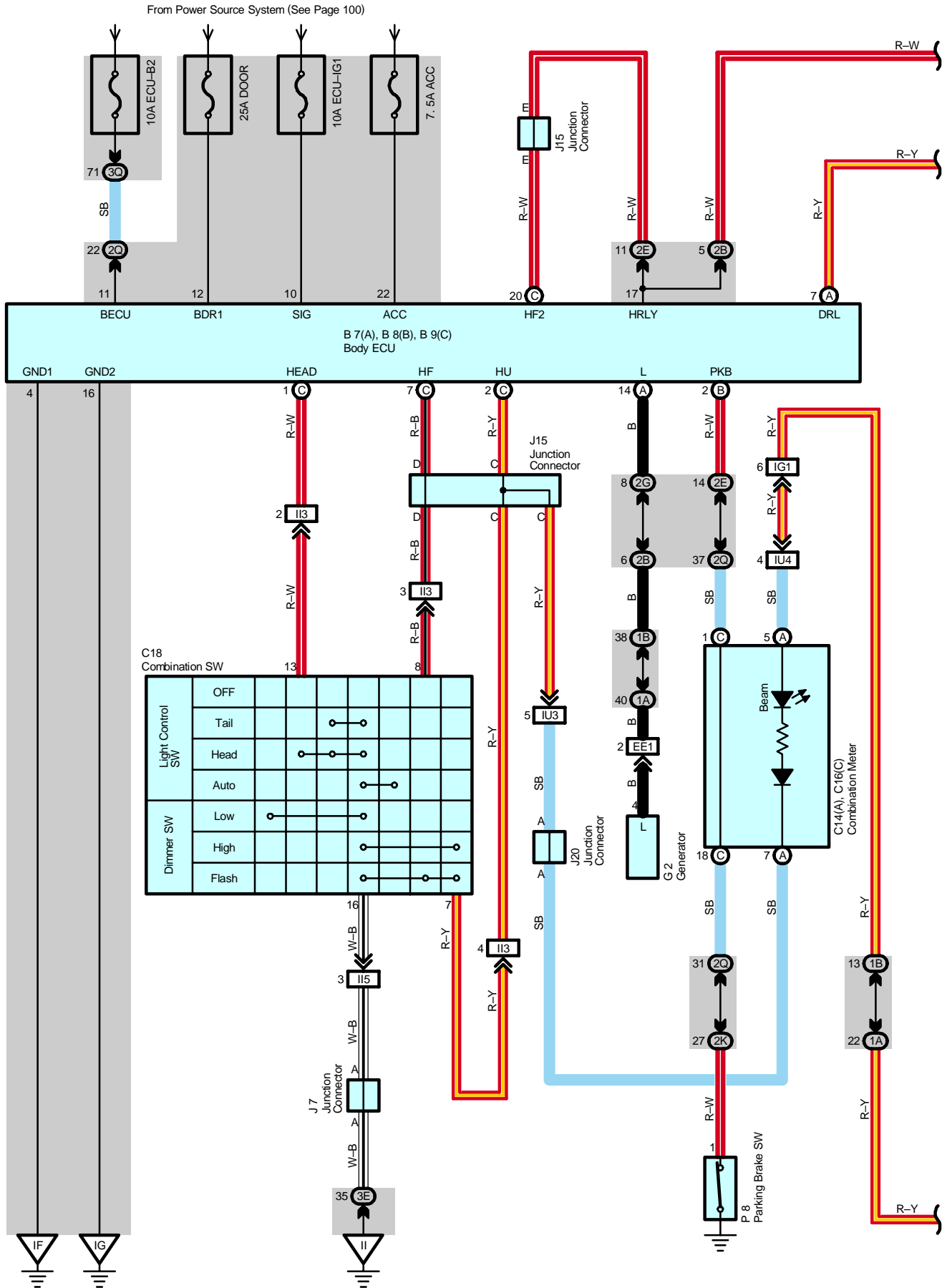

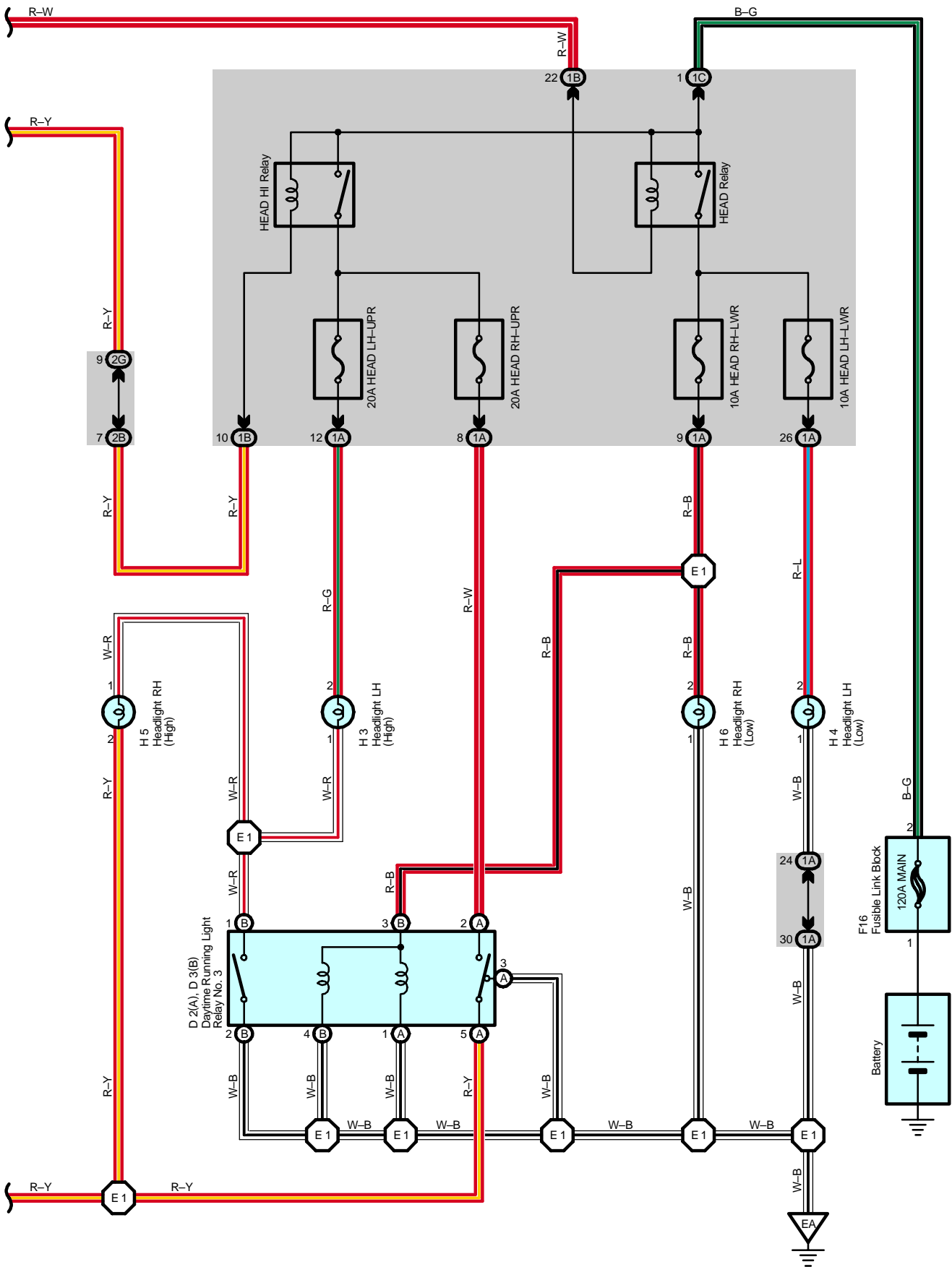

# Headlight with Daytime Running Light

## System Outline

### Daytime Running Light Operation

When the engine is started, a signal from the generator is input into TERMINAL (A) 14 of the body ECU. At this time, if the parking brake lever is pulled up (Parking brake SW ON), the body ECU is not activated, and the daytime running light system does not operate.

When the parking brake lever is released (Parking brake SW OFF), a signal is input into TERMINAL (B) 2 of the body ECU. This activates the body ECU and the headlight turns on.

## Service Hints

### C18 Combination SW

13-16 : Closed with light control SW at HEAD position

8-16 : Closed with dimmer SW at FLASH position

7-16 : Closed with dimmer SW at HIGH or FLASH position

## ○ : Parts Location

Code	See Page	Code	See Page	Code	See Page
B7	A 70	D2	A 68	H5	69
B8	B 70	D3	B 68	H6	69
B9	C 70	F16	68	J7	72
C14	A 71	G2	68	J15	72
C16	C 71	H3	69	J20	72
C18	71	H4	69	P8	75

## ○ : Junction Block and Wire Harness Connector

Code	See Page	Junction Block and Wire Harness (Connector Location)
1A	24	Engine Room Main Wire and Engine Room J/B (Engine Compartment Left)
1B	24	Engine Room No.2 Wire and Engine Room J/B (Engine Compartment Left)
1C		
2B	28	Engine Room No.2 Wire and Cowl Side J/B LH (Left Kick Panel)
2E	28	Dash Wire and Cowl Side J/B LH (Left Kick Panel)
2G		
2K	28	Floor No.1 Wire and Cowl Side J/B LH (Left Kick Panel)
2Q	30	Instrument Panel Integration Wire and Cowl Side J/B LH (Left Kick Panel)
3E	40	Dash Wire and Cowl Side J/B RH (Right Kick Panel)
3Q	42	Instrument Panel Integration Wire and Cowl Side J/B RH (Right Kick Panel)

## □ : Connector Joining Wire Harness and Wire Harness

Code	See Page	Joining Wire Harness and Wire Harness (Connector Location)
EE1	78	Engine Room Main Wire and Alternator Wire (Near the Battery)
IG1	82	Engine Room No.2 Wire and Dash Wire (Behind the Combination Meter)
II3	82	Dash Wire and Column Wire (Near the Ignition SW)
II5		
IU3	84	Instrument Panel Integration Wire and Dash Wire (Behind the Glove Box)
IU4		

## ▽ : Ground Points

Code	See Page	Ground Points Location
EA	78	Front Right Side of Fender Apron
IF	80	Set Bolt of Cowl Side J/B LH
IG		
II	80	Set Bolt of Cowl Side J/B RH



**: Splice Points**

Code	See Page	Wire Harness with Splice Points	Code	See Page	Wire Harness with Splice Points
E1	<a href="#">78</a>	Engine Room Main Wire			