

RELAY LOCATIONS

[Engine Compartment]

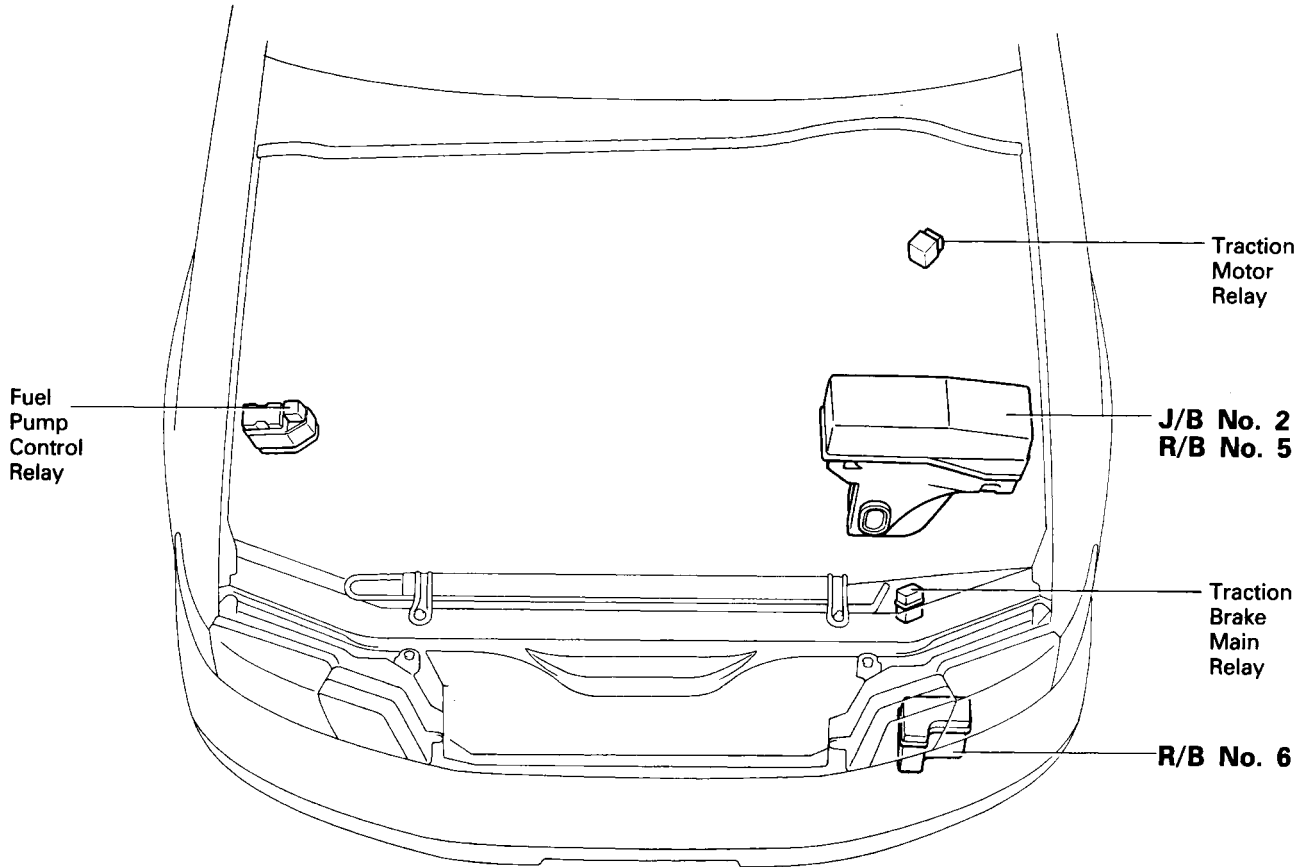

[Body]

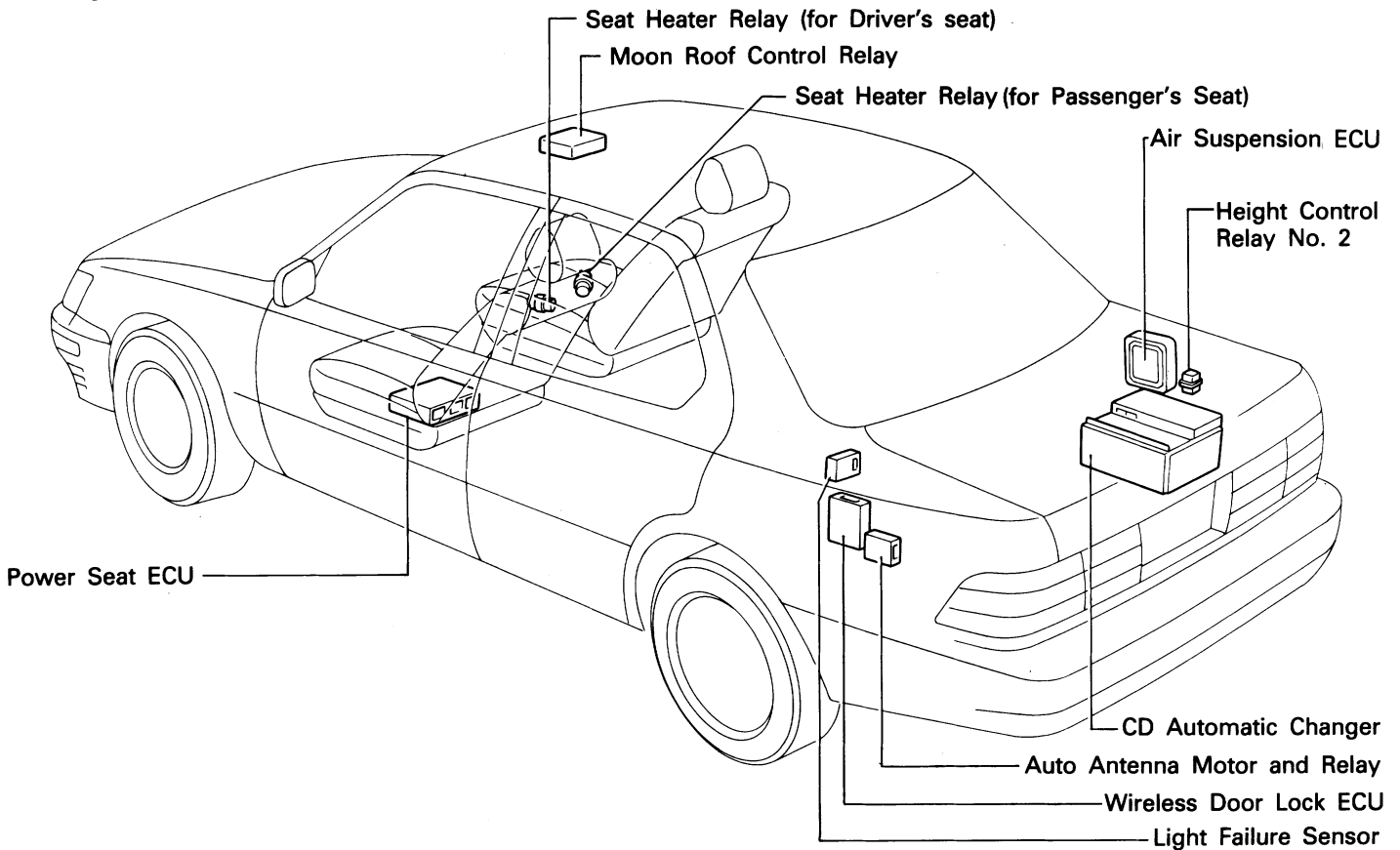

[Instrument Panel]

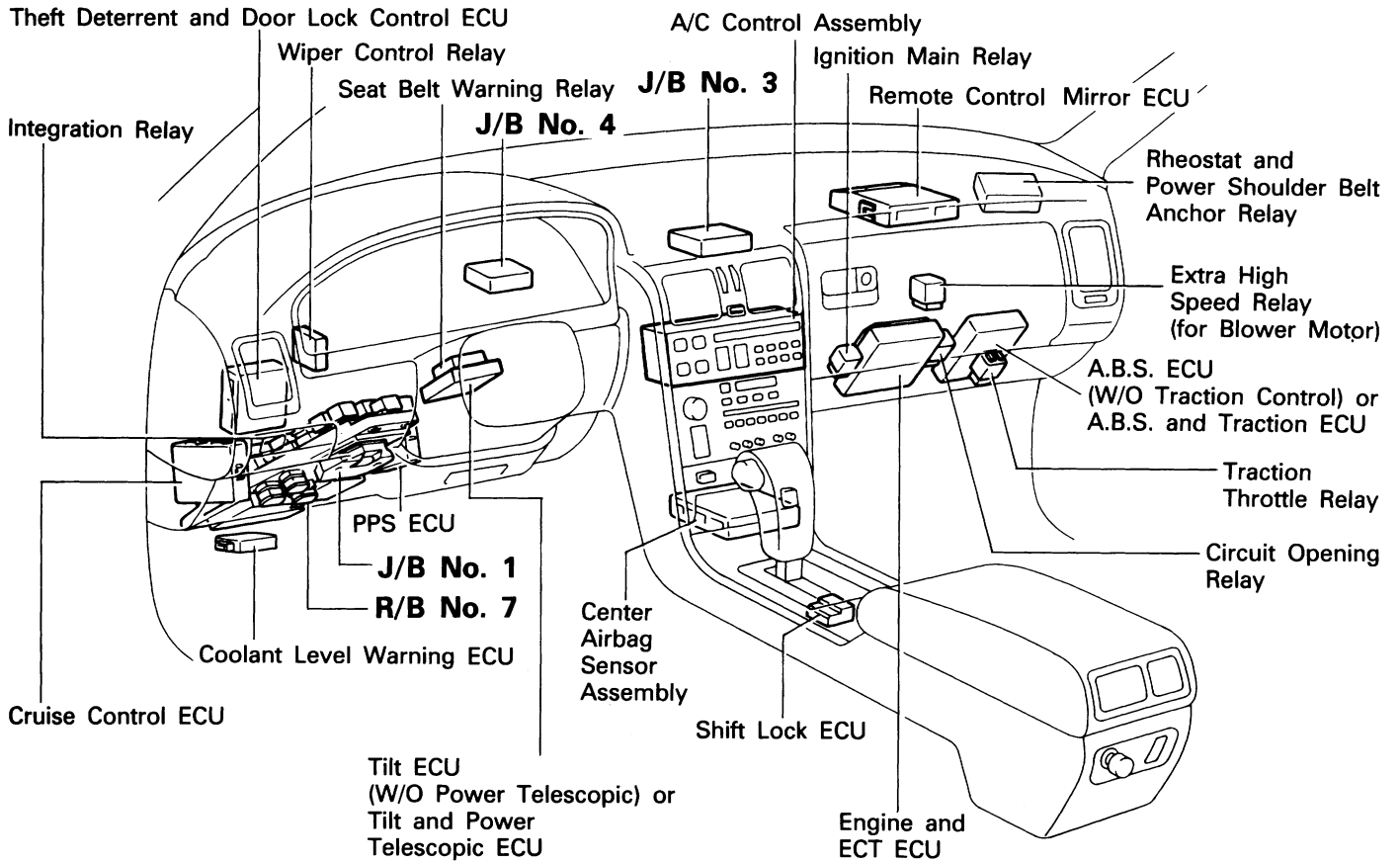

⑥ : R/B No. 6 Under the Headlight LH (See Page 16)

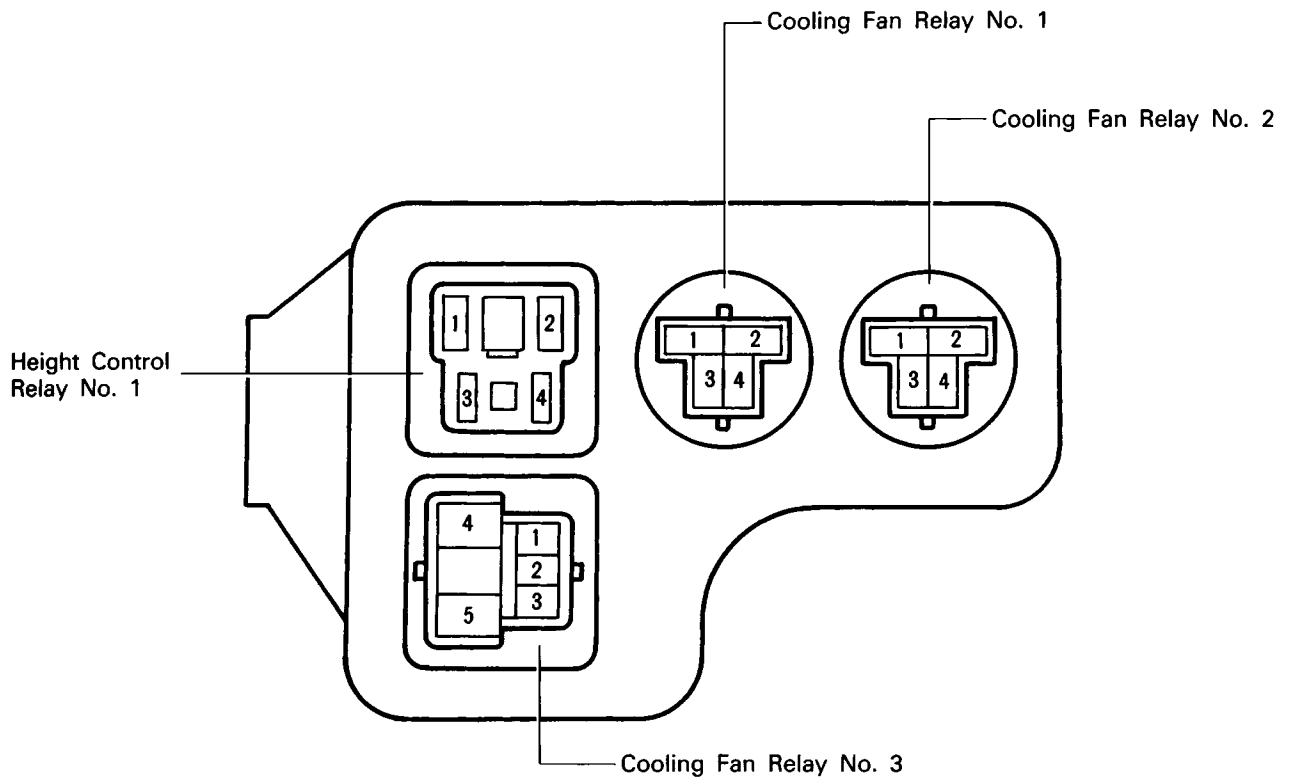

RELAY LOCATIONS

○ : J/B No. 1	Left Side of Steering Column Tube (See Page 17)
⑦ : R/B No. 7	Right Side of J/B No. 1 (See Page 17)

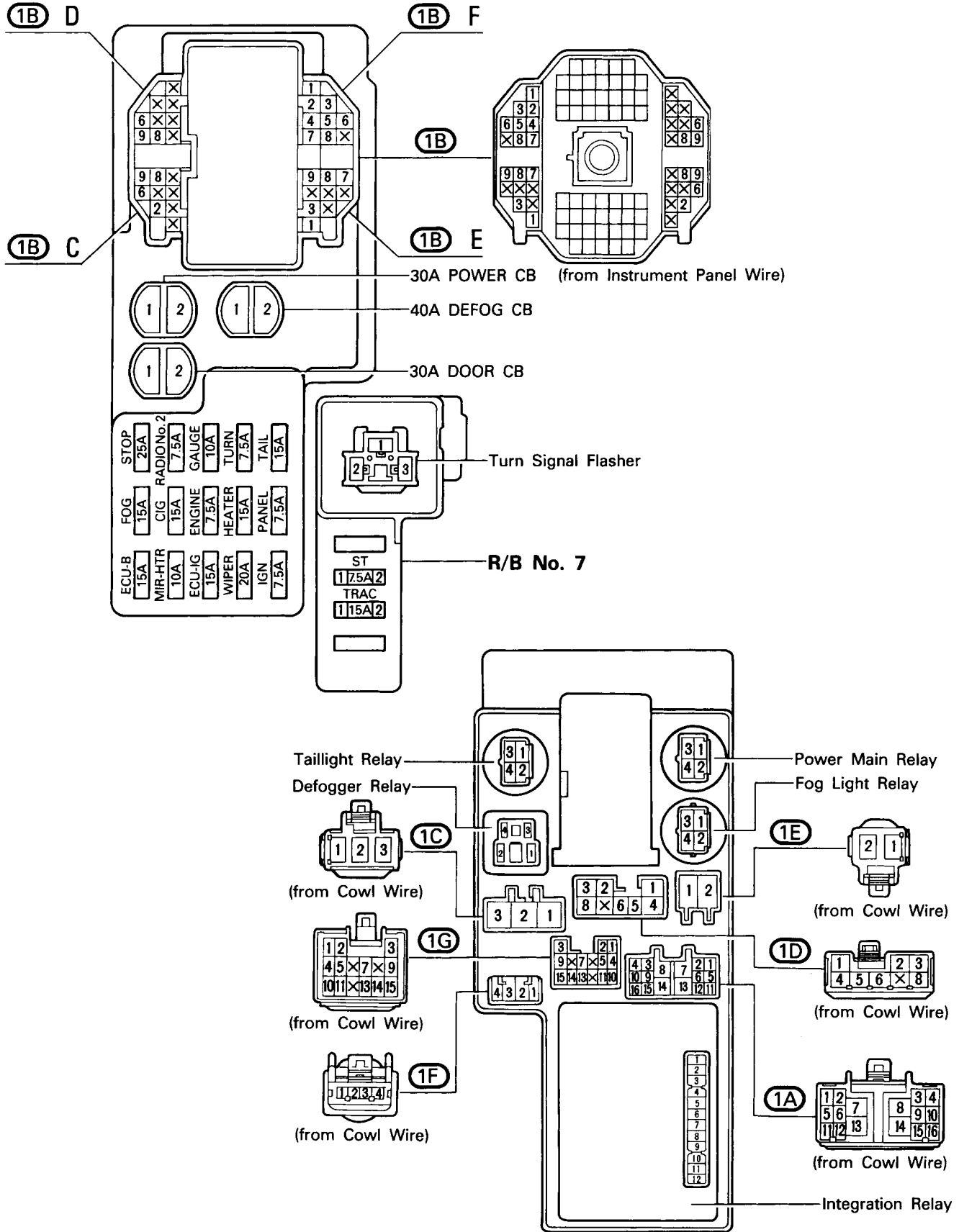

[J/B No. 1 Inner Circuit]

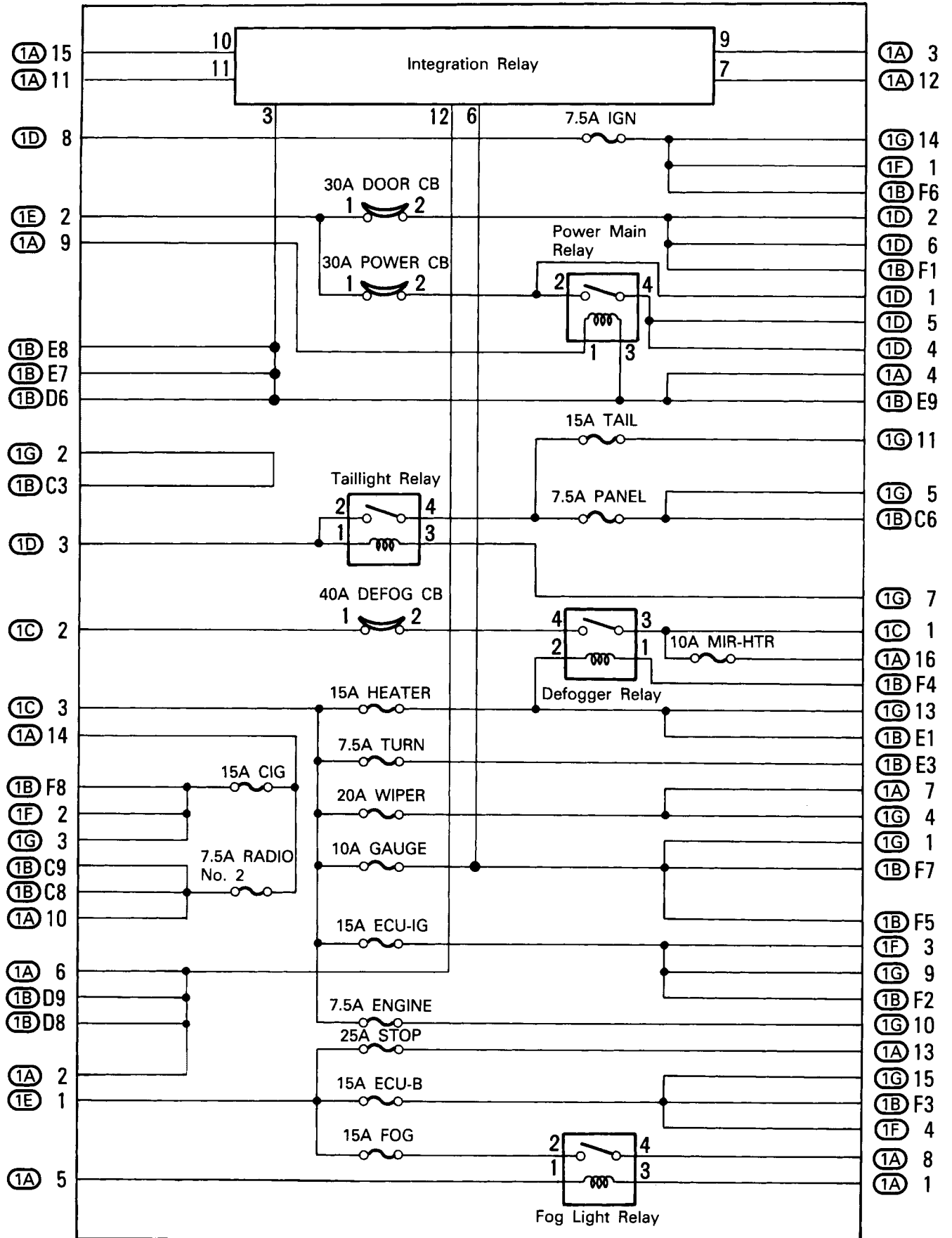

RELAY LOCATIONS

○ : J/B No. 2	Engine Compartment Left (See Page 16)
⑤ : R/B No. 5	Near the J/B No. 2 (See Page 16)

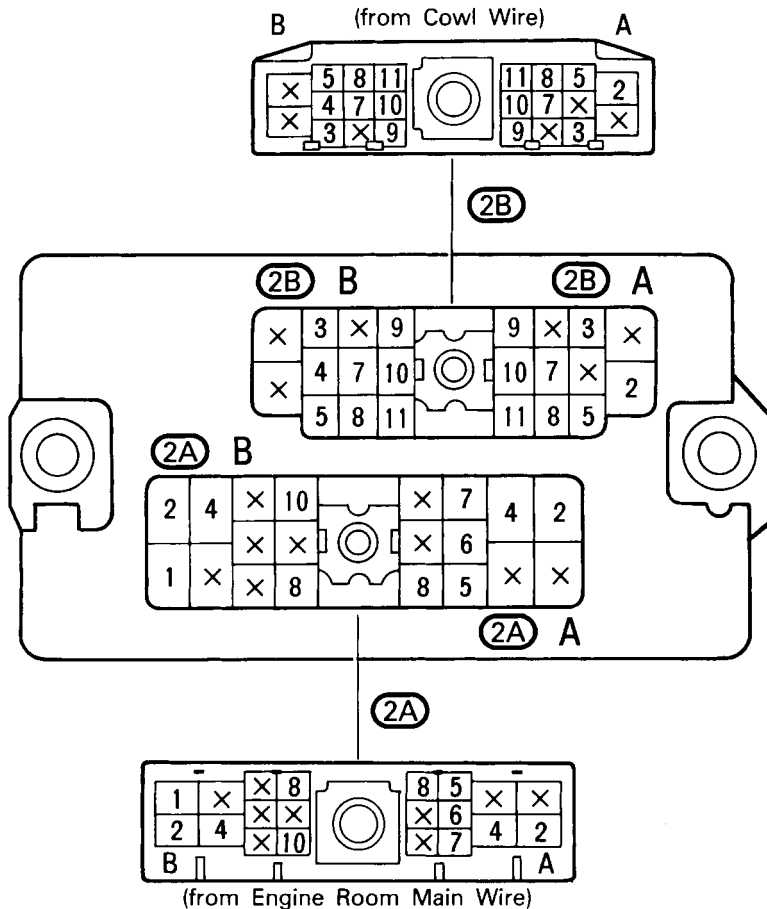
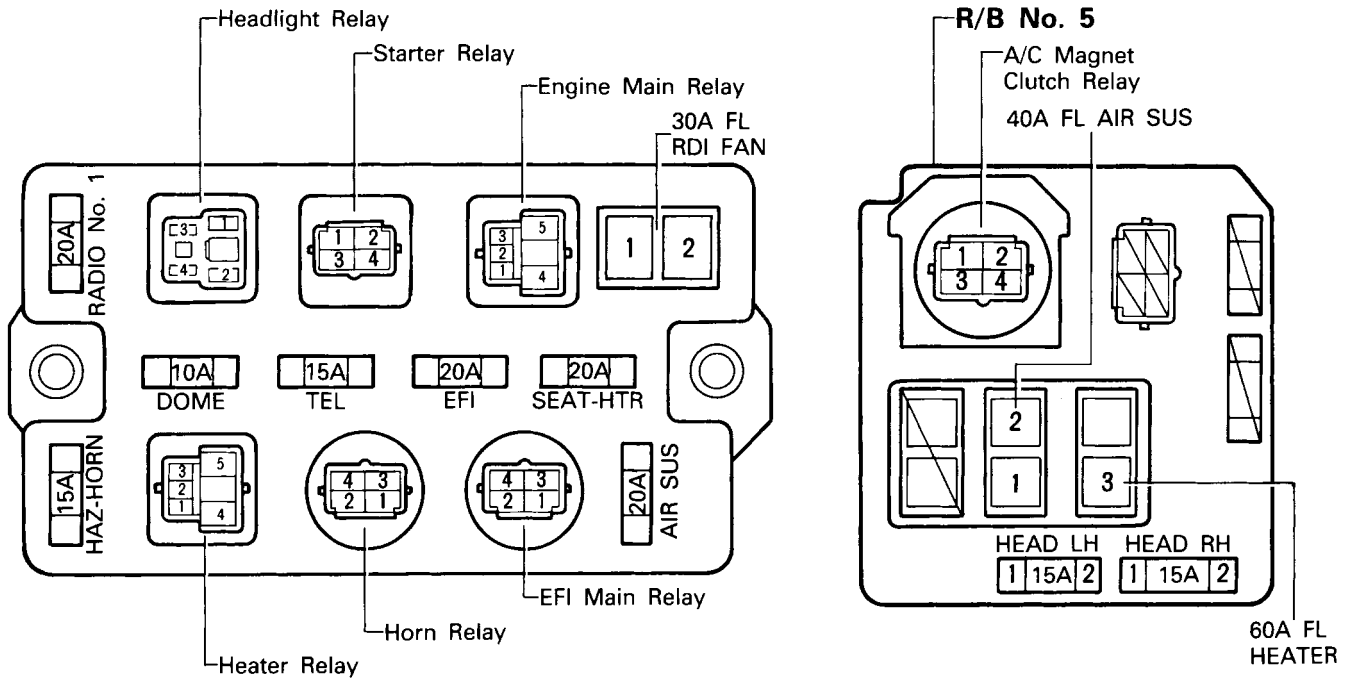

[J/B No. 2 Inner Circuit]

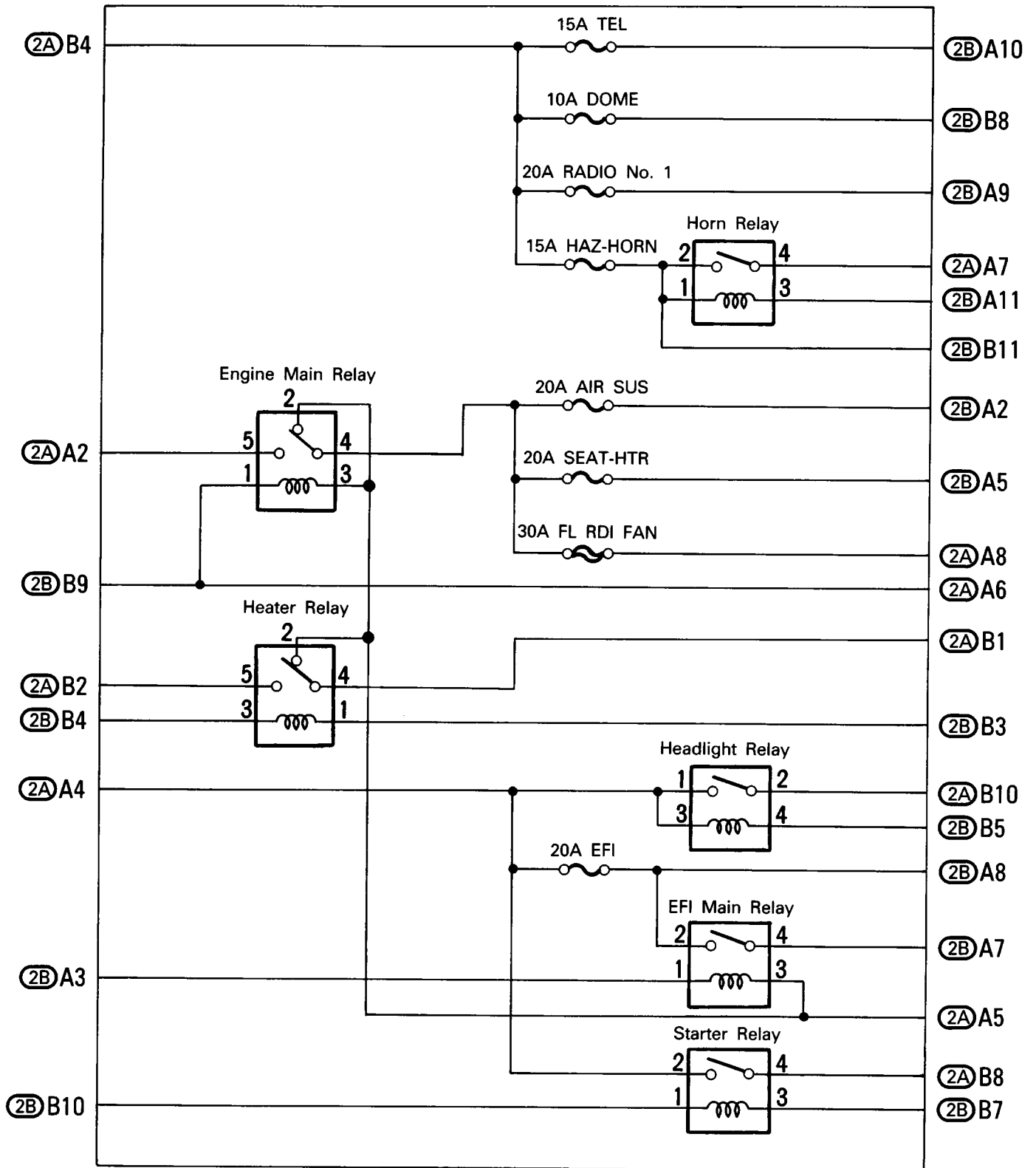

RELAY LOCATIONS

○ : J/B No. 3 Behind the Instrument Panel (See Page 17)

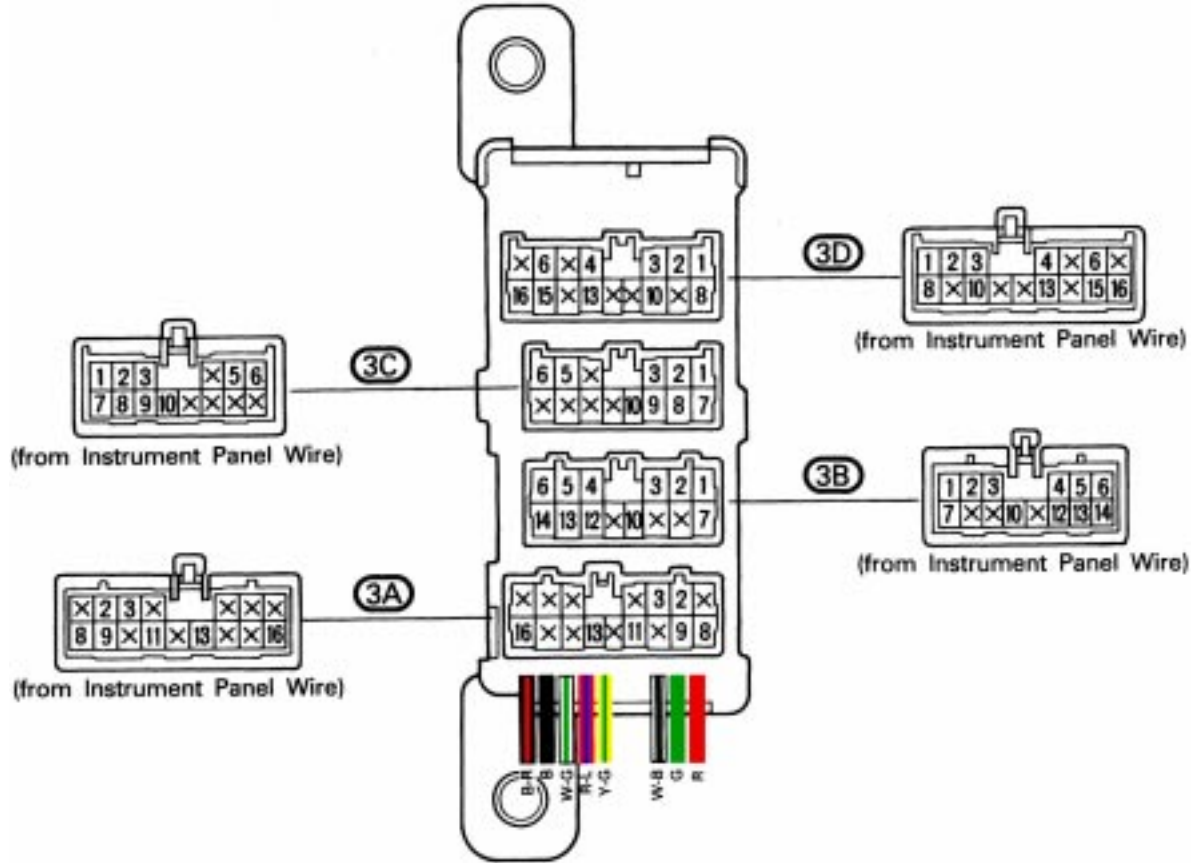

[J/B No. 3 Inner Circuit]

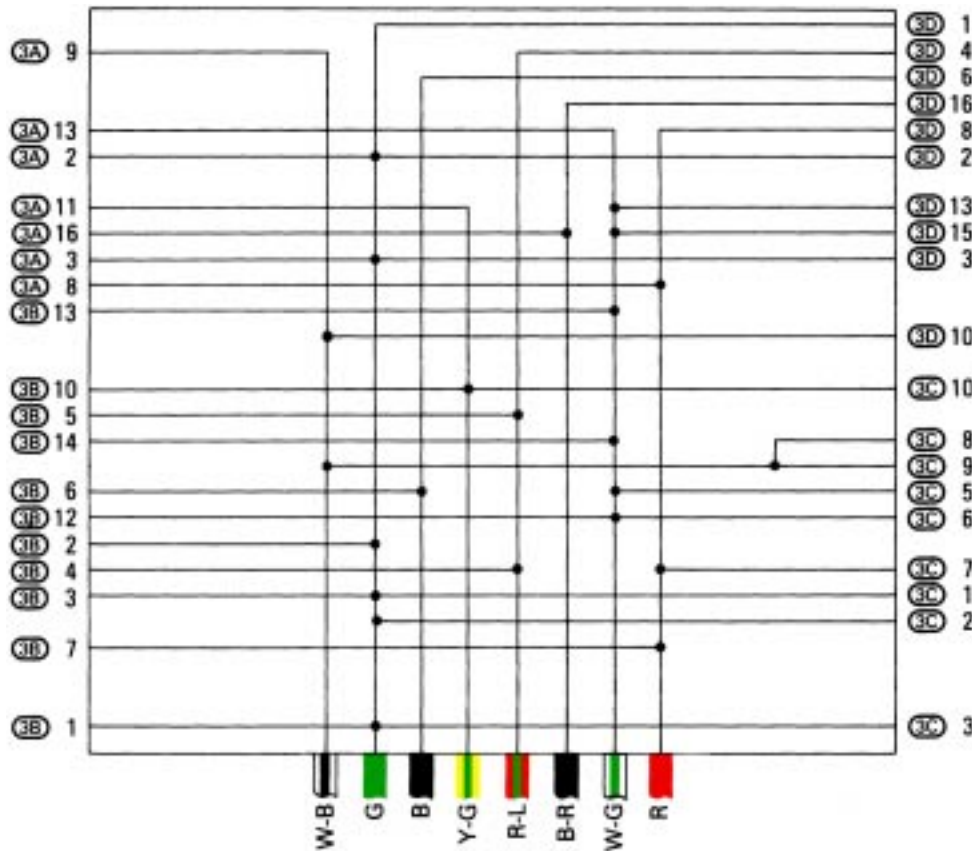

○ : J/B No. 4

Behind the Combination Meter (See Page 17)

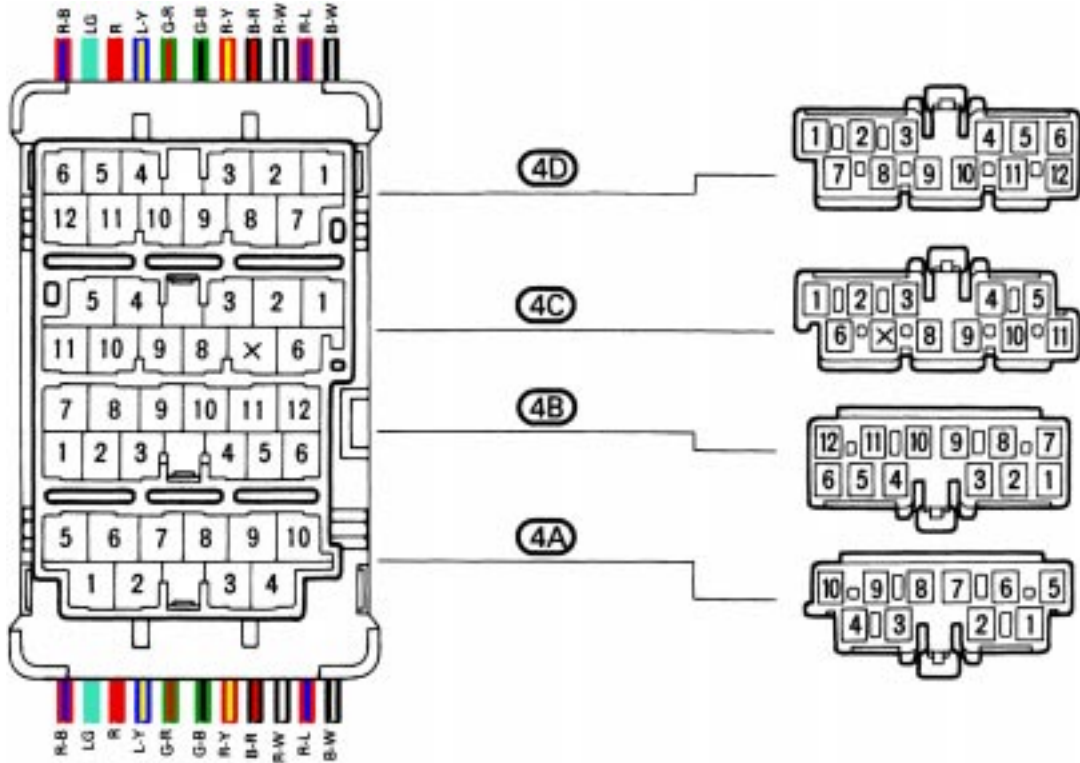

[J/B No. 4 Inner Circuit]

