

PRE-CHECK

1. DIAGNOSIS SYSTEM

(a) Description

- When troubleshooting Multiplex (OBD (M-OBD)) vehicles, the only difference from the usual troubleshooting procedure is that you connect to the vehicle the hand-held tester, and read off various data output from the vehicle's engine ECU.
- The vehicle's on-board computer lights up check engine warning light (CHK (ENG)) on the instrument panel when the computer detects a malfunction in the computer itself or in drive system components. In addition to an indication of the CHK (ENG) lighting up when a malfunction is detected, the applicable Diagnostic Trouble Codes (DTC) recorded in the engine ECU memory (See page DI-17). If the malfunction has been repaired, the CHK ENG goes off automatically but the DTCs remain recorded in the engine ECU memory.

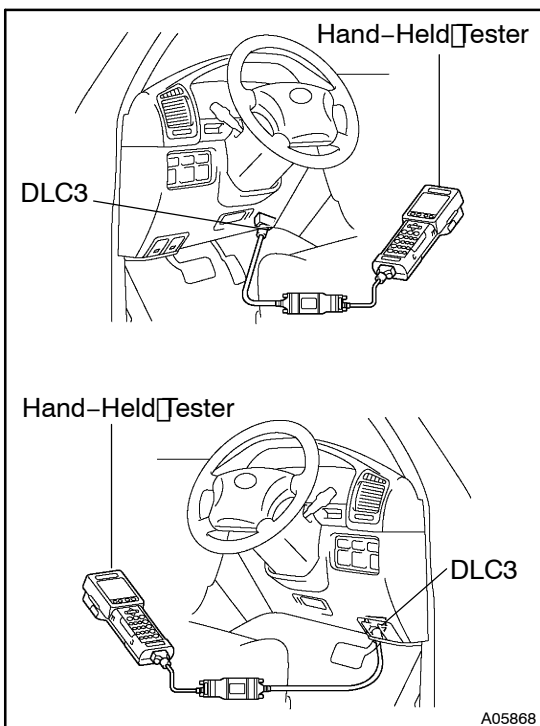

- To check the DTCs, connect the hand-held tester to Data Link Connector 3 (DLC3) on the vehicle or read the diagnostic trouble code which is indicated on the multi information display when TC and CG terminals on the DLC3 are connected. The hand-held tester also enables you to erase the DTCs and check frozen frame data and various forms of engine data. (For operating instructions, see the instruction book.)
- The diagnosis system operates in normal mode during normal vehicle use. It also has a check (test) mode for technicians to simulate malfunction symptoms and troubleshoot. Most DTCs use 2 trip detection logic* to prevent erroneous detection, and ensure thorough malfunction detection. By switching the engine ECU to check (test) mode using hand-held tester when troubleshooting, the technician can cause the CHK ENG light up for a malfunction that is only detected once or momentarily. (Hand-held tester only) (See step 2)
- *2 trip detection logic: When a logic malfunction is first detected, the malfunction is temporarily stored in the engine ECU memory. If the same malfunction is detected again during the second drive test, this second detection causes the CHK ENG light up. The 2 trip repeats the same mode a 2nd time. (However, the IG switch must be turned OFF between the 1st trip and 2nd trip.)

- Freeze frame data:
Freeze frame data records the engine condition when a malfunction is detected.
Because freeze frame data records the engine conditions (fuel system, calculator load, Water temperature, fuel trim, engine speed, vehicle speed, etc.) when the malfunction is detected, when troubleshooting it is useful for determining whether the vehicle was running or stopped, the engine warmed up or not, the air-fuel ratio lean or rich, etc. at the time of the malfunction.

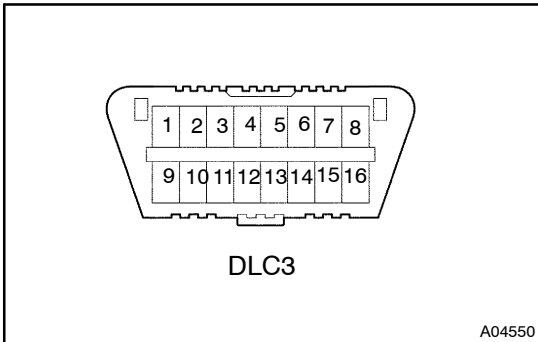

- (b) Check the DLC3.
The vehicle's engine ECU uses ISO 14230 for communication. The terminal arrangement of DLC3 complies with SAE J1962 and matches the ISO 14230 format.

Terminal No.	Connection / Voltage or Resistance	Condition
7	Bus ⊕ Line / Pulse generation	During transmission
4	Chassis Ground ↔ Body Ground / 1 Ω or less	Always
16	Battery Positive ↔ Body Ground / 9 ~ 14 V	Always

HINT:

If your display shows "UNABLE TO CONNECT TO VEHICLE" when you have connected the cable of the hand-held tester to DLC3, turned the ignition switch ON and operated the hand-held tester, there is a problem on the vehicle side or tool side.

- If communication is normal when the tool is connected to another vehicle, inspect DLC3 on the original vehicle.
- If communication is still not possible when the tool is connected to another vehicle, the problem is probably in the tool itself, so consult the Service Department listed in the tool's instruction manual.

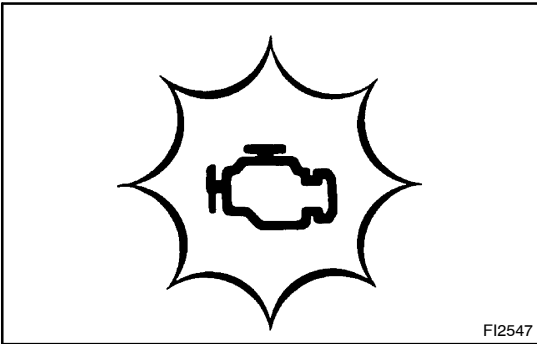

2. INSPECT DIAGNOSIS (Normal Mode)

(a) Check the DTC using hand-held tester.

NOTICE:

Hand-held tester only: When the diagnosis system is switched from normal mode to check (test) mode, it erases all DTCs and freeze frame data recorded in normal mode. So before switching modes, always check the DTCs and freeze frame data, and note them down.

- (1) Prepare the hand-held tester.
- (2) Connect the hand-held tester to DLC3.
- (3) Turn the ignition switch ON and push the hand-held tester main switch ON.
- (4) Use the hand-held tester to check the DTCs and freeze frame data, note them down. (For operating instructions, see the hand-held tester instruction book.)
- (5) See page DI-17 to confirm the details of the DTCs.

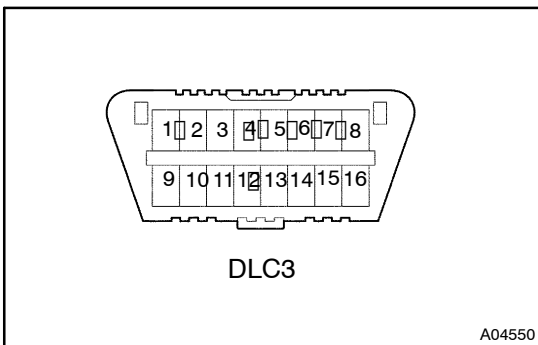

(b) Check the DTC

- (1) Turn the ignition switch ON.
- (2) Using SST, connect between terminals 13 (TC) and 4 (CG) of DLC3.
SST 09843-18040
- (3) Read the DTC on the multiinformation display.

HINT:

- If a DTC is not indicated, check the TC terminal circuit (See page DI-22).
- If a code No.89 is indicated, read the number of blinks of the 2nd STRT indication (only for A/T)/ETCS indicator (only for M/T) to get the DTC for the electric throttle control system (ETCS).

NOTICE:

When simulating symptoms with out a hand-held tester to check the DTCs, use normal mode. For code on the DTC chart subject to "2 trip detection logic", turn the ignition switch OFF after the symptom is simulated the first time. Then repeat the simulation process again. When the problem has been simulated twice, the CHK ENG light up and the DTCs are recorded in the engine ECU.

- (c) Check the DTC for ETCS
 (1) Turn ignition switch ON.

HINT:

If the 2nd STRT indicator (only for A/T)/ETCS indicator (only for M/T) does not light up, troubleshoot the combination meter (See page DI-21).

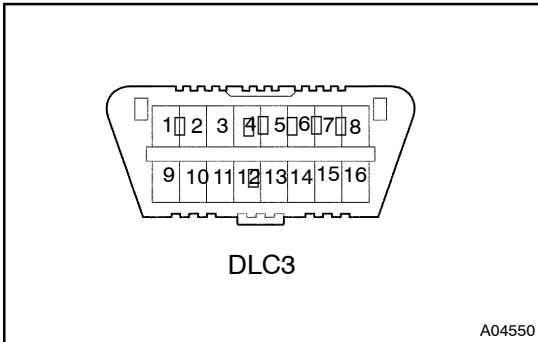

- (2) Using SST, connect between terminals 13 (TC) and 4 (CG) of DLC3.

SST 09843-18040

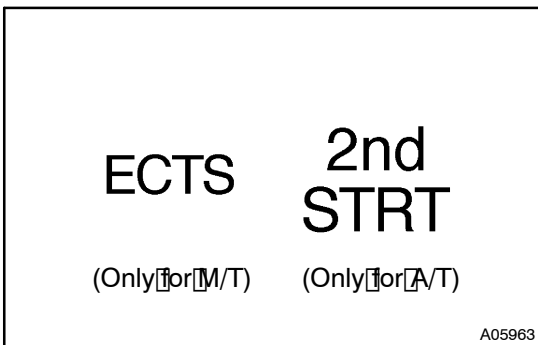

- (3) Read the diagnostic trouble code from 2nd STRT indicator (only for A/T)/ETCS indicator (only for M/T) on the combination meter.

HINT:

If a DTC is not output, check the TC terminal circuit (See page DI-22).

- (4) Check details of the malfunction using the DTC chart on page DI-17.
 (5) After completing the check, disconnect terminals 13 (TC) and 4 (CG) and turn off the display.

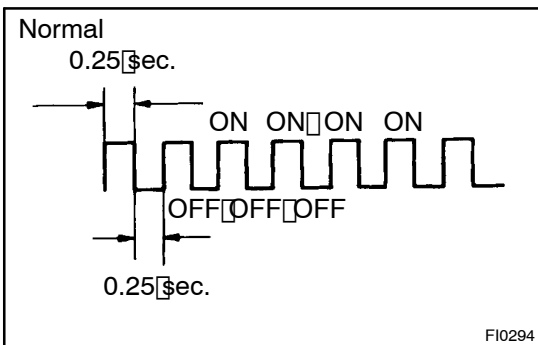

HINT:

In the event of 2 or more malfunction codes, indication will begin from the smaller numbered code and continue in order to the larger.

- (d) Clear the DTC.
 The DTCs and frozen frame data will be erased by either actions.
- (1) Operating the hand-held tester to erase the codes. (See the hand-held tester's instruction book for operating instructions.)
 (2) Disconnecting the battery terminals of EFI and THROTTLE fuses.

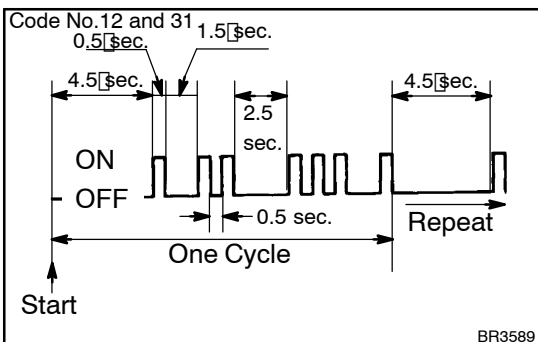

NOTICE:

If the hand-held tester switches the engine ECU from normal mode to check (test) mode or vice-versa, or if the ignition switch is turned from ON to ACC or OFF during check (test) mode, the DTCs and frozen frame data will be erased.

3. INSPECT DIAGNOSIS (Check (Test) Mode)

HINT:

Hand-held tester only:

Compared to the normal mode, the check (test) mode has an increased sensitivity to detect malfunctions.

Furthermore, the same diagnostic items which are detected in the normal mode can also be detected in the check (test) mode.

- (a) Check the DTC.
 - (1) Initial conditions
 - Battery positive voltage 11V or more.
 - Throttle valve fully closed.
 - Transmission in "P" or "N" position.
 - Air conditioning switched OFF.
 - (2) Turn the ignition switch OFF.
 - (3) Prepare the hand-held tester.
 - (4) Connect the hand-held tester to the DLC3.
 - (5) Turn the ignition switch ON and push the hand-held tester main switch ON.
 - (6) Switch the hand-held tester normal mode to check (test) mode.

NOTICE:

If the hand-held tester switches the engine ECU from normal mode to check (test) mode or vice-versa, or if the ignition switch is turned from ON to ACC or OFF during check (test) mode, the DTCs and frozen frame data will be erased.

- (7) Start the engine.
- (8) Simulate the conditions of the malfunction described by the customer.

NOTICE:

Leave the ignition switch ON until you have checked the DTCs, etc.

- (9) After simulating the malfunction conditions, use the hand-held tester diagnosis selector to check the DTCs and frozen frame data, etc.

HINT:

Take care not to turn the ignition switch OFF. Turning the ignition switch OFF switches the diagnosis system from check (test) mode to normal mode. so all DTCs, etc. are erased.

- (10) After checking the DTC, inspect the applicable circuit.

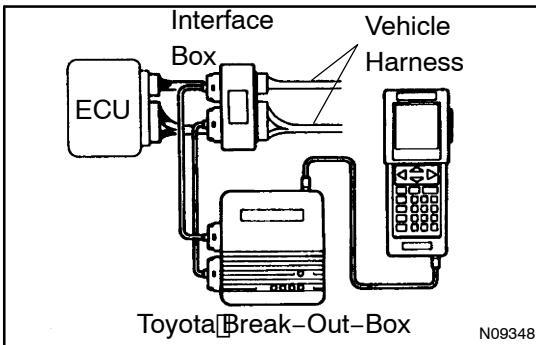

(b) Engine ECU Terminal Values Measurement Using Break-Out-Box and Hand-Held Tester

- (1) Hook up the break-out-box and hand-held tester to the vehicle.
- (2) Read the engine ECU input/output values by following the prompts on the tester screen.

HINT:

- Hand-held tester has a "Snapshot" function. This records the measured values and is effective in the diagnosis of intermittent problems.
- Please refer to the hand-held tester/break-out-box operator's manual for further details.

4. FAIL-SAFE CHART

If any of the following codes is recorded, the engine ECU enters fail-safe mode.

DTC No.	Fail-Safe Operation	Fail-Safe Deactivation Conditions
P0100/31	Ignition timing fixed at 5° BTDC	Returned to normal condition
P0110/24	Intake air temperature is fixed at 20°C (68°F)	Returned to normal condition
P0115/22	Water temperature is fixed at 80°C (176°F)	Returned to normal condition
P0120/41	VTA is fixed at 0°	The following condition must be repeated at least 2 times consecutively when closed throttle position switch is OFF: VTA \geq 0.1 V and \leq 0.95 V
P0135/21 P0141/21 P0155/28 P0161/28 (w/ TWC)	The heater circuit in which an abnormality is detected is turned off	Ignition switch OFF
P0325/52 P0330/53	Max. timing retardation	Ignition switch OFF
P1300/14 P1305/15 P1310/14 P1315/14 P1320/14 P1325/14 P1330/14 P1340/14	Fuel cut	Returned to normal condition

5. CHECK FOR INTERMITTENT PROBLEMS

HAND-HELD TESTER only:

By putting the vehicle's engine ECU in check (test) mode, 1 trip detection logic is possible instead of 2 trip detection logic and sensitivity to detect open circuits is increased. This makes it easier to detect intermittent problems.

- (1) Clear the DTCs.
- (2) Set the check (test) mode.
- (3) Perform a simulation test (See page N-9)
- (4) Check the connector and terminal (See page N-19)
- (5) Handle the connector (See page N-19)

6. BASIC INSPECTION

When the malfunction code is not confirmed in the DTC check, troubleshooting should be performed in the order for all possible circuits to be considered as the causes of the problems. In many cases, by carrying out the basic engine check shown in the following flow chart, the location causing the problem can be found quickly and efficiently. Therefore, use of this check is essential in engine troubleshooting.

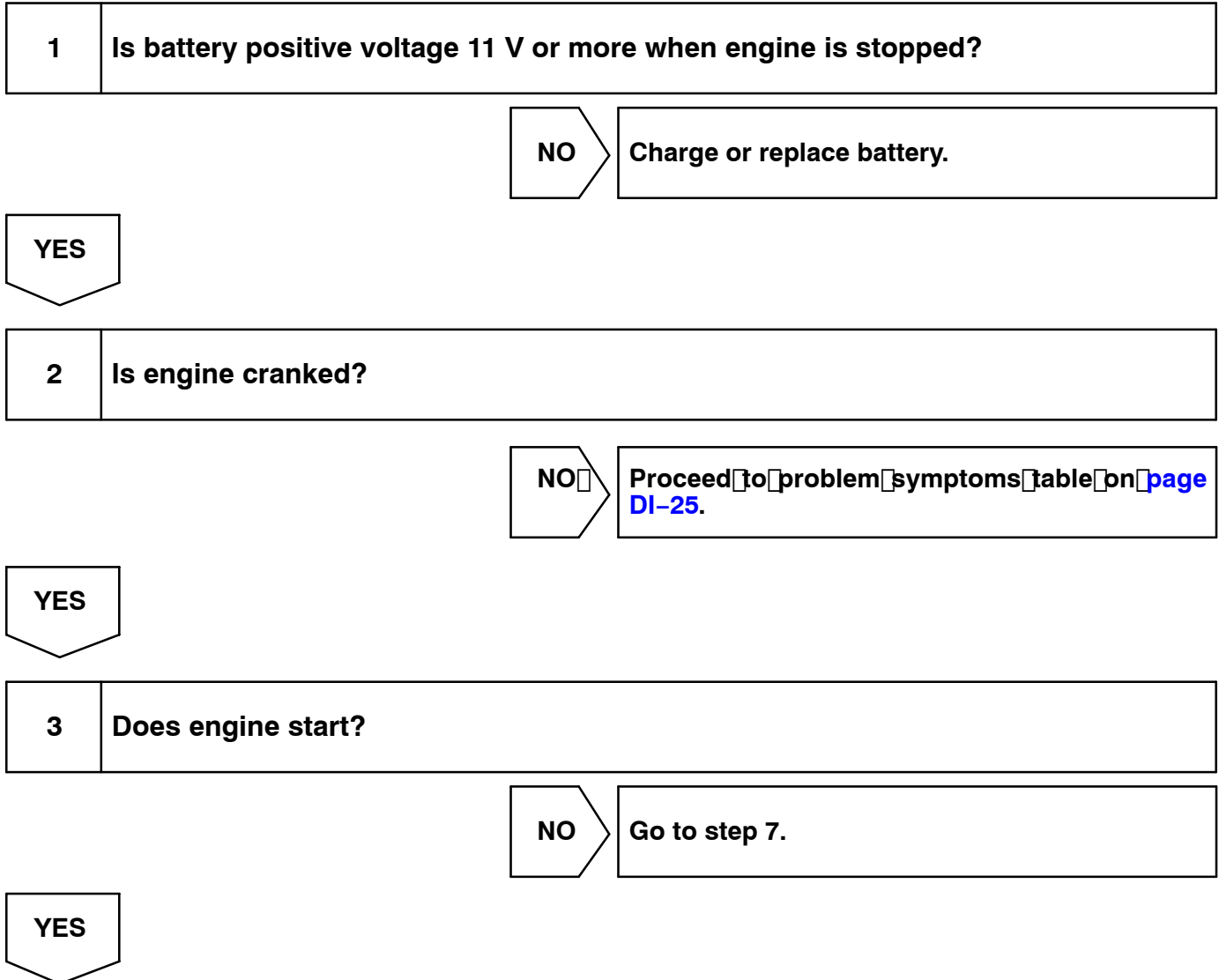

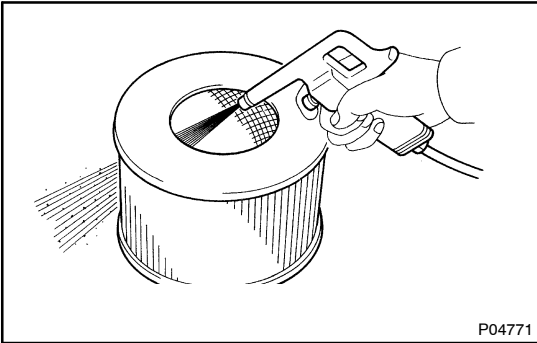
4 Check air filter.**PREPARATION:**

Remove the air filter.

CHECK:

Visual check that the air filter is not dirty or excessive oily.

HINT:

If necessary, clean the filter.

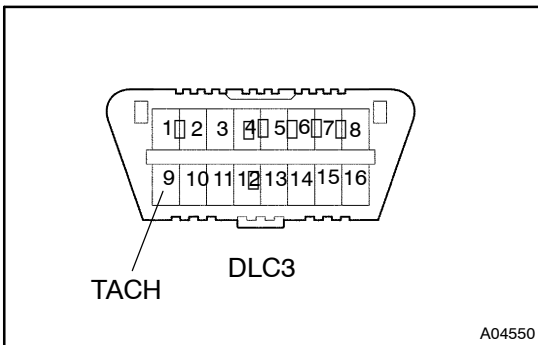
NG**Repair or replace****OK****5 Check idle speed.****PREPARATION:**

- Warm up the engine to normal operating temperature.
- Switch off all accessories.
- Switch off air conditioning.
- Shift transmission into "N" position.
- Connect the hand-held tester to the DLC3 on the vehicle.
- If you have no hand-held tester, connect tachometer test probe to terminal 9 (TACH) of the DLC3.
SST 09843-18030

NOTICE:

As some tachometers are not compatible with this ignition system, we recommend that you confirm the compatibility of your until before use.

CHECK:

Check the idle speed.

OK:

Idle speed: 650 – 750 rpm

NG

Proceed to problem symptoms table on page [DI-25](#).

OK

6 Check ignition timing.

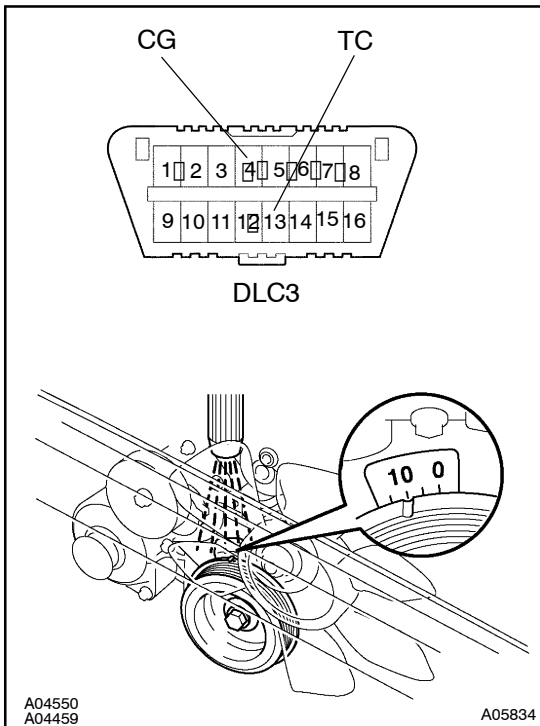

PREPARATION:

- Warm up the engine to normal operating temperature.
- Shift transmission into "N" position.
- Keep the engine speed at idle.
- Using SST, connect terminals 13 (TC) and 4 (CG) of the DLC3.
SST 09843-18040
- Using a timing light, connect the tester to the ignition coil connector wire (See page EM-11).

CHECK:

Check ignition timing.

OK:

Ignition timing: 10° BTDC at idle

NG

Proceed to page G-1 and continue to troubleshoot.

OK

Proceed to problem symptoms table on page DI-25.

7	Check fuel pressure.
----------	-----------------------------

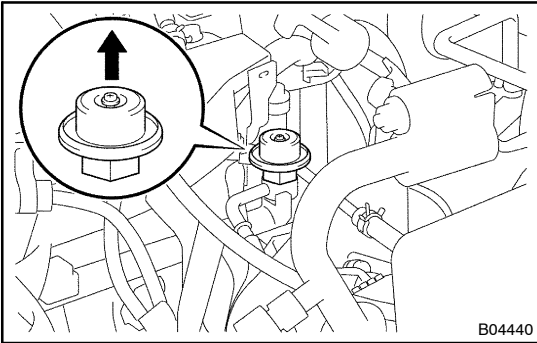
**PREPARATION:**

- (a) Be sure that enough fuel is in the tank.
- (b) Connect the hand-held tester to the DLC3.
- (c) Turn the ignition switch ON and push hand-held tester main switch ON.
- (d) Use ACTIVE TEST mode to operate the fuel pump.
- (e) Please refer to the hand-held tester operator's manual for further details.
- (f) If you have no hand-held tester, connect the positive (+) and negative (-) leads from the battery to the fuel pump connector [\[See page FI-7\]](#)

CHECK:

Check that pulsation damper screw rises up when fuel pump operates.

HINT:

At this time, you will hear a fuel flowing noise.

NG	Proceed to page FI-7 and continue to troubleshoot.
-----------	---

OK

8 Check for spark.

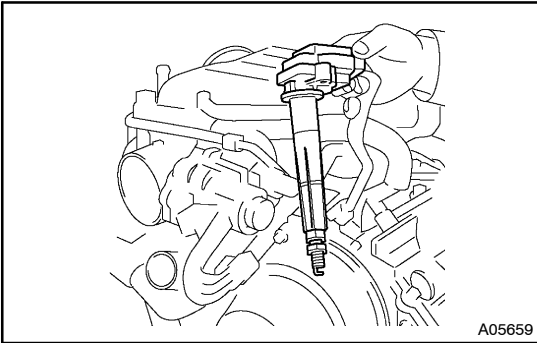

PREPARATION:

- Remove the ignition coil from the spark plug.
- Remove the spark plug.
- Install the spark plug to the ignition coil.
- Disconnect the injector connector.
- Ground the spark plug.

CHECK:

Check if spark occurs while engine is being cranked.

NOTICE:

To prevent excess fuel being injected from the injectors during this test, don't crank the engine for more than 5 ~ 10 seconds at a time.

NG

Proceed to [page IG-1](#) and continue to troubleshoot.

OK

Proceed to [problem symptoms table on page DI-25](#).

7. ENGINE OPERATING CONDITION

NOTICE:

The values given below for "Normal Condition" are representative values, so a vehicle may still be normal even if its value varies from those listed here. So do not decide whether a part is faulty or not solely according to the "Normal Condition" here.

Hand-held tester display	Measurement Item	Normal Condition*
FUEL SYS #1	Fuel System Bank 1 OPEN: Air-fuel ratio feedback stopped CLOSED: Air-fuel ratio feedback operating	Idling after warming up: CLOSED
FUEL SYS #2	Fuel System Bank 2 OPEN: Air-fuel ratio feedback stopped CLOSED: Air-fuel ratio feedback operating	Idling after warming up: CLOSED
CALC LOAD	Calculator Load: Current intake air volume as a proportion of max. intake air volume	Idling: 12.0 ~ 18.0 % Racing without load (2,500rpm): 11.0~ 17.0 %
COOLANT TEMP.	Water Temp. Sensor Value	After warming up: 80 ~ 95°C (176 ~ 203°F)
SHORT FT #1	Short-term Fuel Trim Bank 1	0 ± 20 %
LONG FT #1	Long-term Fuel Trim Bank 1	0 ± 20 %
SHORT FT #2	Short-term Fuel Trim Bank 2	0 ± 20 %
LONG FT #2	Long-term Fuel Trim Bank 2	0 ± 20 %

*: If no conditions are specifically stated for "Idling", it means the shift lever is at N or P position, the A/C switch is OFF and all accessory switches are OFF.

DIAGNOSTICS - ENGINE

Hand-held tester display	Measurement Item	Normal Condition*
ENGINE SPD	Engine Speed	Idling: 650 ~ 750 rpm
VEHICLE SPD	Vehicle Speed	Vehicle stopped: 0 km/h (0 mph)
IGN ADVANCE	Ignition Advance: Ignition Timing of Cylinder No. 1	Idling: BTDC 5 ~ 15°
INTAKE AIR	Intake Air Temp. Sensor Value	Equivalent to ambient temp.
AFM	Air Flow Rate Through Air Flow Meter	Idling: 4.5 ~ 5.5 gm/sec. Racing without load (2,500 rpm): 13.0 ~ 20.0 gm/sec.
THROTTLE POS	Voltage Output of Throttle Position Sensor Calculated as a percentage: 0 V → 0 %, 5 V → 100 %	Throttle fully closed: 8 ~ 20 % Throttle fully open: 64 ~ 96 %
O2S B1, S1	Voltage Output of Oxygen Sensor Bank 1, Sensor 1	Idling: 0.1 ~ 0.9 V
O2S B1, S2	Voltage Output of Oxygen Sensor Bank 1, Sensor 2	Driving (50 km/h, 31 mph): 0.1 ~ 0.9 V
O2S B2, S1	Voltage Output of Oxygen Sensor Bank 2, Sensor 1	Idling: 0.1 ~ 0.9 V
O2S B2, S2	Voltage Output of Oxygen Sensor Bank 2, Sensor 2	Driving (50 km/h, 31 mph): 0.1 ~ 0.9 V
O2FT B1, S1	Oxygen Sensor Fuel Trim Bank 1, Sensor 1 (Same as SHORT FT #1)	0 ± 20 %
O2FT B2, S1	Oxygen Sensor Fuel Trim Bank 2, Sensor 1 (Same as SHORT FT #2)	0 ± 20 %
INJECTOR	Fuel injection time for cylinder No.1	Idling: 2.1 ~ 3.9 ms
STARTER SIG	Starter Signal	Cranking: ON
A/C SIG	A/C Switch Signal	A/C ON: ON
PNP SW	Park/Neutral Position Switch Signal	P or N position: ON
CTP	Closed Throttle Position	Throttle fully closed: ON
STOP LIGHT SW	Stop Light Switch Signal	Stop light switch ON: ON
FC IDL	Fuel Cut Idle: Fuel cut when throttle valve fully closed, during deceleration	Fuel cut operating: ON
FC TAU	Fuel Cut TAU: Fuel cut during very light load	Fuel cut operating: ON
FUEL PUMP	Fuel Pump Signal	Idling: ON
EVAP (PURGE) VSV	EVAP VSV Signal	VSV operating: ON

*: If no conditions are specifically stated for "Idling", it means the shift lever is at N or P position, the A/C switch is OFF and all accessory switches are OFF.

Hand-held tester display	Measurement Item	Normal Condition*
THROTTLE POS #2	Throttle position sensor No.2 output voltage	Throttle fully closed: 2.0 ~ 2.9 V Throttle fully open: 4.7 ~ 5.1 V
ACCEL POS	Accelerator pedal position sensor No.1 output voltage	Accelerator pedal released: 0.3 ~ 0.9 V Accelerator pedal depressed: 3.2 ~ 4.8 V
ACCEL POS #2	Accelerator pedal position sensor No.2 output voltage	Accelerator pedal released: 1.8 ~ 2.7 V Accelerator pedal depressed: 4.7 ~ 5.1 V
THROTTLE TARGET POS	Target position of throttle valve	Idling: 0.4 ~ 1.1 V
THROTTLE OPEN DUTY	Throttle motor opening duty ratio	Throttle fully closed: 0 % When accelerator pedal is depressed, duty ratio is increased
THROTTLE CLOSE DUTY	Throttle motor closed duty ratio	Throttle fully closed: 0 % When accelerator pedal is quick released, duty ratio is increased
THROTTLE MOTOR CTL	Whether or not throttle motor control is permitted	Idling: ON
THROTTLE CLUTCH CTL	Whether or not magnetic clutch control is permitted	Idling: ON
+BM	Whether or not electric throttle control system power is inputted	Idling: ON
ACCEL IDL	Whether or not accelerator pedal position sensor is detecting idle	Idling: ON
THROTTLE IDL	Whether or not throttle position sensor is detecting idle	Idling: ON
FAIL #1	Whether or not fail safe function is executed	ETCS is failed: ON
FAIL #2	Whether or not fail safe function is executed	ETCS is failed: ON
THROTTLE LEAN VALUE	Throttle fully closed learning value	0.4 ~ 0.8 V
ACCEL LEAN VALUE	Accelerator fully closed learning value	0.4 ~ 0.8 V
THROTTLE MOTOR	Throttle motor control current	Idling: 0 ~ 3.0 A
ETCS MAG CLUTCH	Magnetic clutch control current	0.8 ~ 1.0 A
TOTAL FT B1	Total Fuel Trim Bank 1: Average value for fuel trim system of bank 1	Idling: 0.5 ~ 1.4
TOTAL FT B2	Total Fuel Trim Bank 2: Average value for fuel trim system of bank 2	Idling: 0.5 ~ 1.4
O2 LR B1, S1	Oxygen Sensor Lean Rich Bank 1, Sensor 1 Response time for oxygen sensor output to switch from lean to rich	Idling after warming up: 0 ~ 1,000 msec.
O2 LR B2, S1	Oxygen Sensor Lean Rich Bank 2, Sensor 1 Response time for oxygen sensor output to switch from lean to rich	Idling after warming up: 0 ~ 1,000 msec.
O2 RL B1, S1	Oxygen Sensor Rich Lean Bank 1, Sensor 1 Response time for oxygen sensor output to switch from rich to lean	Idling after warming up: 0 ~ 1,000 msec.
O2 RL B2, S1	Oxygen Sensor Rich Lean Bank 1, Sensor 1 Response time for oxygen sensor output to switch from rich to lean	Idling after warming up: 0 ~ 1,000 msec.

*: If no conditions are specifically stated for "Idling", it means the shift lever is at N or P position, the A/C switch is OFF and all accessory switches are OFF.