

Headlight

From Power Source System (See Page 72)

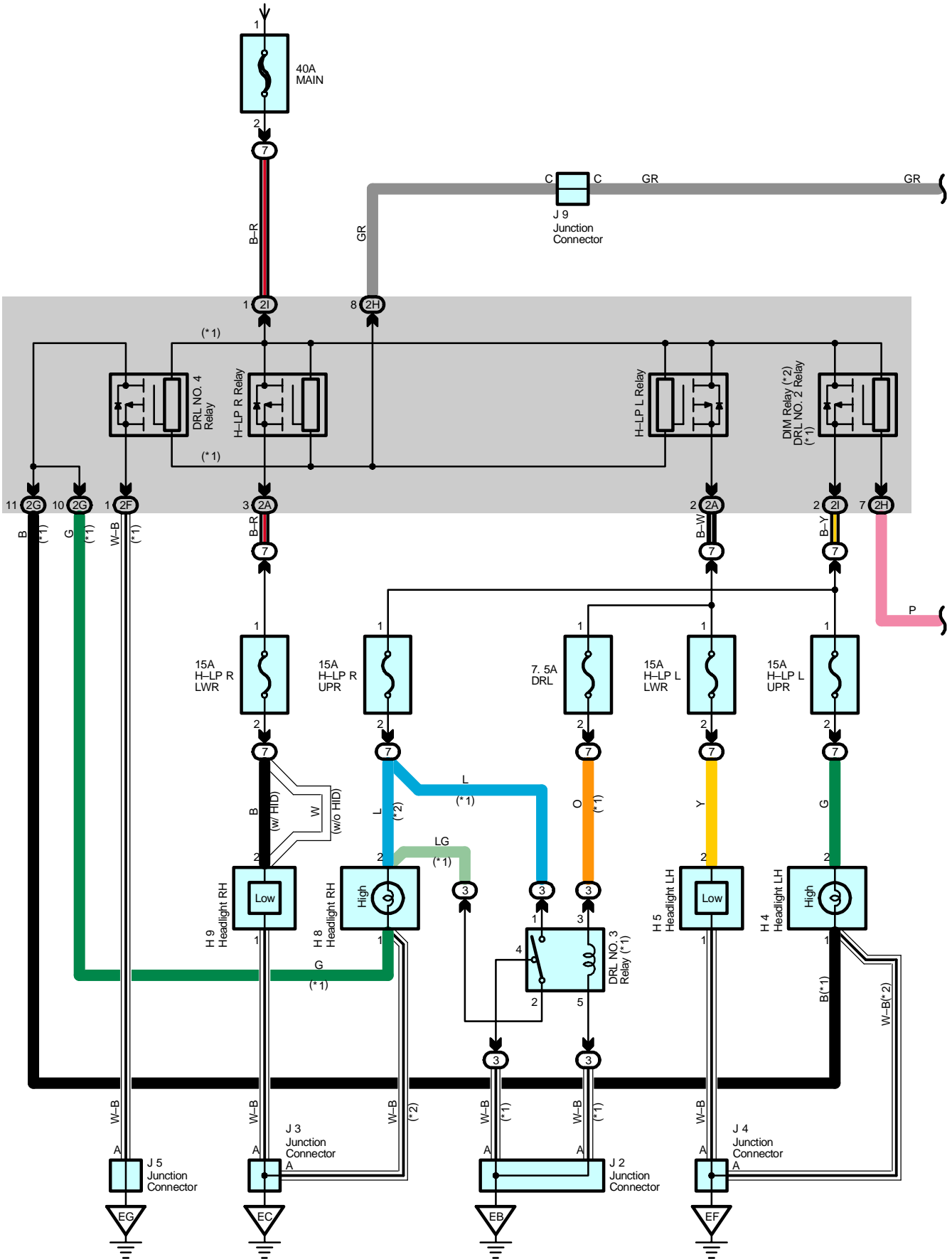

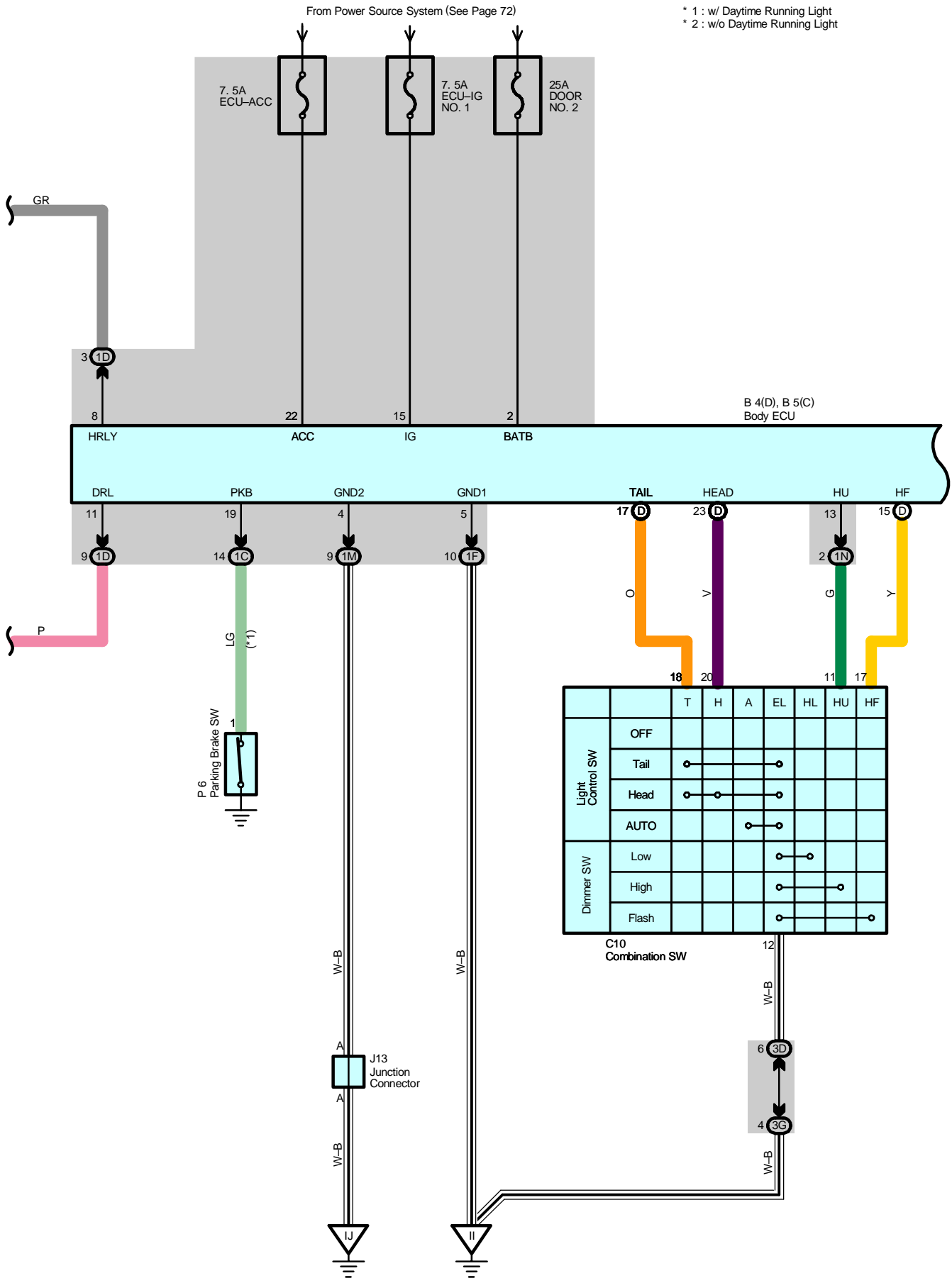

Headlight

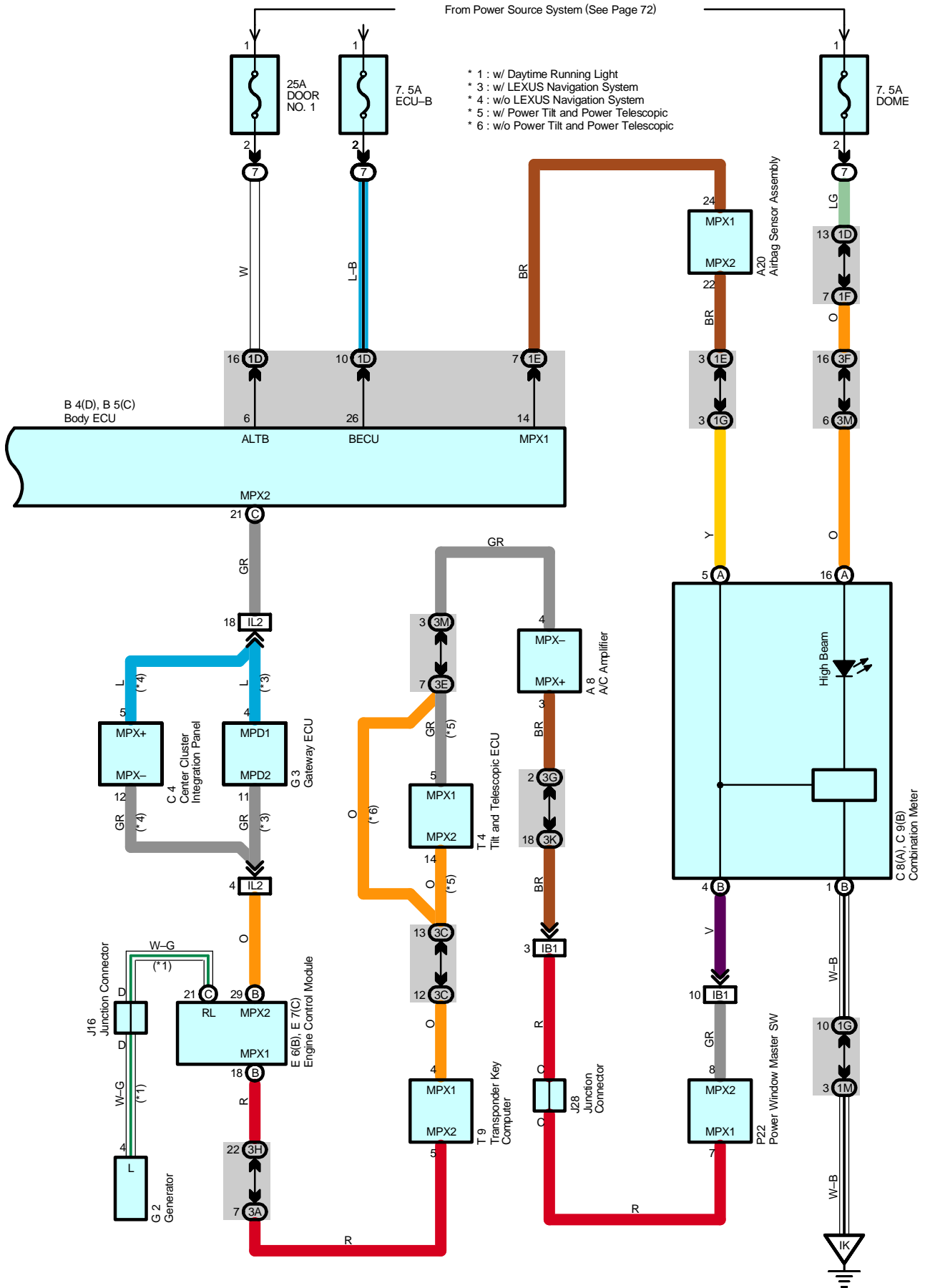

Service Hints

C10 Combination SW

20-12 : Closed with light control SW at HEAD position

17-12 : Closed with dimmer SW at FLASH position

11-12 : Closed with dimmer SW at HIGH position

Power Distributor

Condition of the following four relays can be monitored using mode monitor:

- * DIM relay (w/o daytime running light)
- * DRL NO.2 relay (w/ daytime running light)
- * H-LP L relay
- * H-LP R relay

○ : Parts Location

Code	See Page	Code	See Page	Code	See Page
A8	46	G2	44	J9	48
A20	46	G3	47	J13	48
B4	D 46	H4	44	J16	48
B5	C 46	H5	44	J28	51
C4	47	H8	44	P6	49
C8	A 47	H9	44	P22	52
C9	B 47	J2	45	T4	49
C10	47	J3	45	T9	49
E6	B 47	J4	45		
E7	C 47	J5	45		

○ : Relay Blocks

Code	See Page	Relay Blocks (Relay Block Location)
3	24	R/B No.3 (Engine Compartment Right)
7	22	Fusible Link Block (Engine Compartment Left)

○ : Junction Block and Wire Harness Connector

Code	See Page	Junction Block and Wire Harness (Connector Location)
1C	26	Engine Room Main Wire and Instrument Panel J/B (Lower Finish Panel)
1D		
1E	26	Instrument Panel Wire and Instrument Panel J/B (Lower Finish Panel)
1F		
1G	27	Instrument Panel Wire and J/B No.3 (Behind the Combination Meter)
1M	26	
1N		32
2A	Engine Room Main Wire and J/B No.2 (Engine Compartment Left)	
2F		
2G		
2H		
2I		
3A	34	Instrument Panel Wire and J/B No.3 (Behind the Combination Meter)
3C		
3D		
3E		
3F		
3G		
3H		
3K		
3M		

Headlight

 : Connector Joining Wire Harness and Wire Harness

Code	See Page	Joining Wire Harness and Wire Harness (Connector Location)
IB1	58	Front Door LH Wire and Instrument Panel Wire (Left Kick Panel)
IL2	62	Instrument Panel Wire and Instrument Panel No.2 Wire (Above the Glove Box)

 : Ground Points

Code	See Page	Ground Points Location
EB	56	Near the Headlight RH
EC		
EF	56	Near the Headlight LH
EG		
II	58	Left Kick Panel
IJ	58	Left Side of the Instrument Panel
IK	58	Behind the Combination Meter

