

AIR INDUCTION SYSTEM

Air Flow Meter

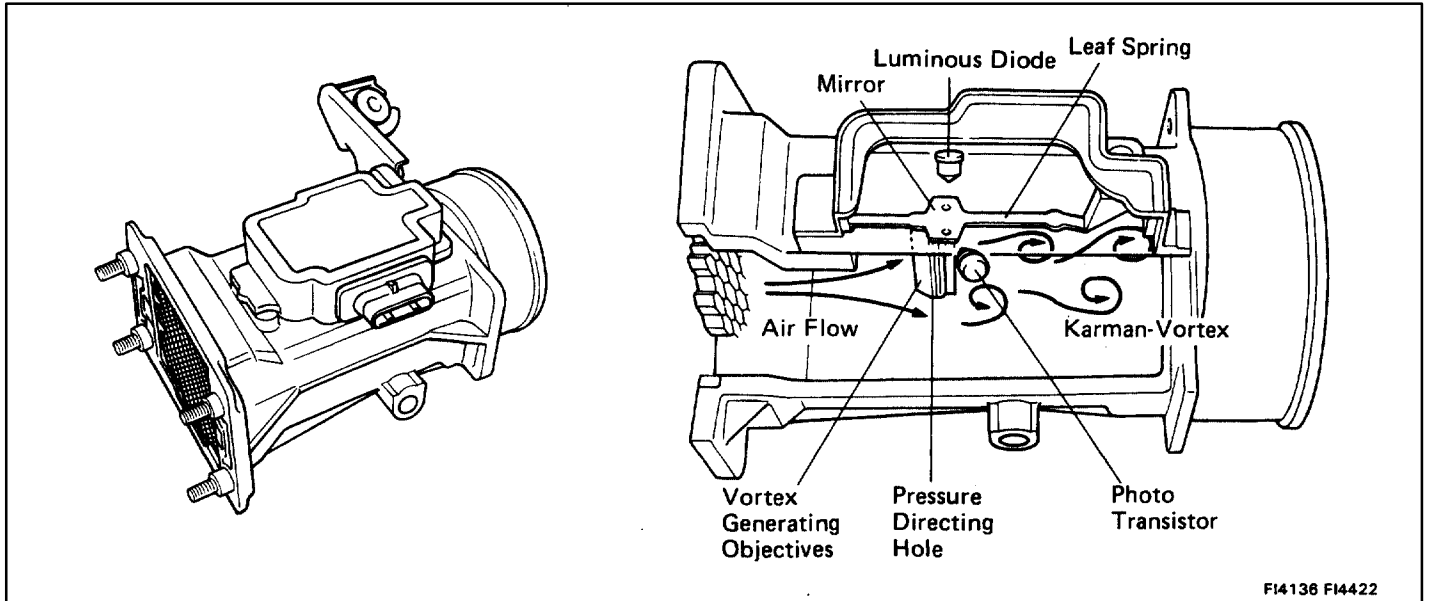

ON-VEHICLE INSPECTION

INSPECTION OF AIR FLOW METER RESISTANCE

- (a) Disconnect the connector from the air flow meter.
- (b) Using an ohmmeter, measure the resistance between terminals THA and E2.

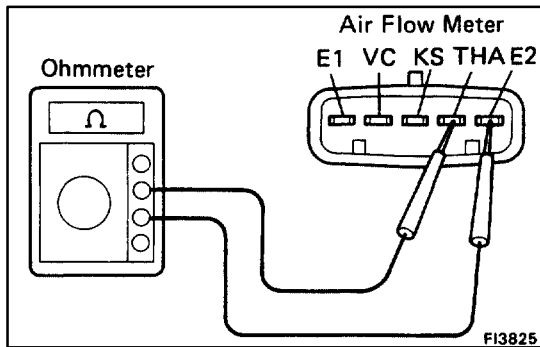

Terminals	Resistance (kΩ)	Temp. (°C/°F)
THA-E2	10-20	-20 (-4)
	4-7	0 (32)
	2-3	20 (68)
	0.9-1.3	40 (104)
	0.4-0.7	60 (140)

If the resistance is not as specified, replace the air flow meter.

- (c) Connect the connector to the air flow meter.

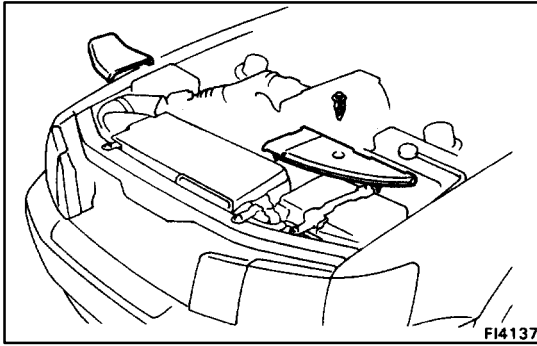

FI4137

REMOVAL OF AIR FLOW METER

1. REMOVE AIR CLEANER COVER AND BATTERY CLAMP COVER

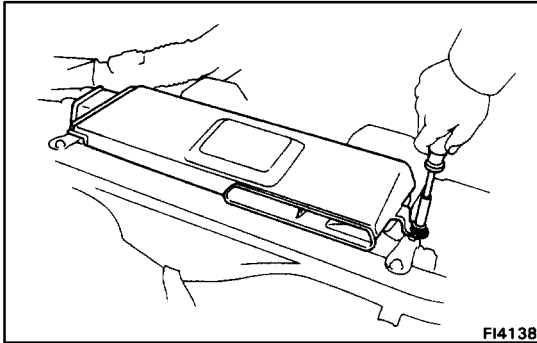

FI4138

2. REMOVE NO.2 AIR CLEANER HOSE

Remove the bolt and remove the No.2 air cleaner hose.

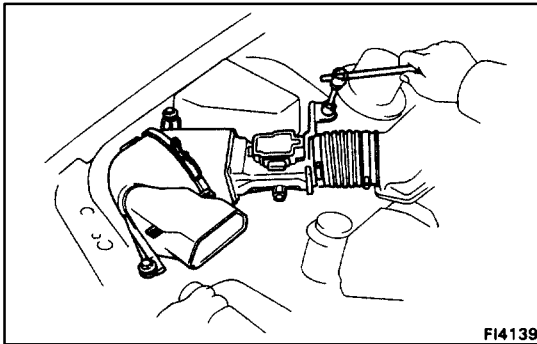

FI4139

3. REMOVE AIR CLEANER WITH AIR FLOW METER

- (a) Disconnect the connector from the air flow meter.
- (b) Remove the three bolts and loosen the clamp.
- (c) Remove the air cleaner case with air flow meter from the intake air connector pipe.

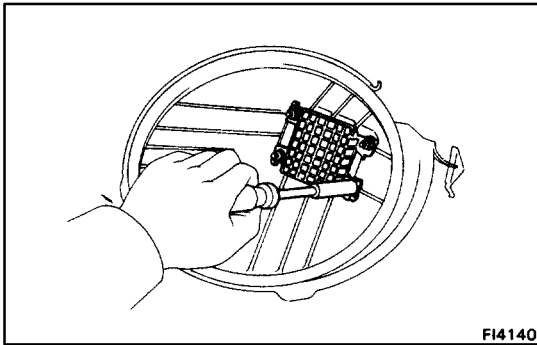

FI4140

4. REMOVE AIR FLOW METER

- (a) Remove the air cleaner case and air element.
- (b) Release the lock plate calking and remove the four nuts. Remove the protector, air cleaner cap and gasket from the air flow meter.

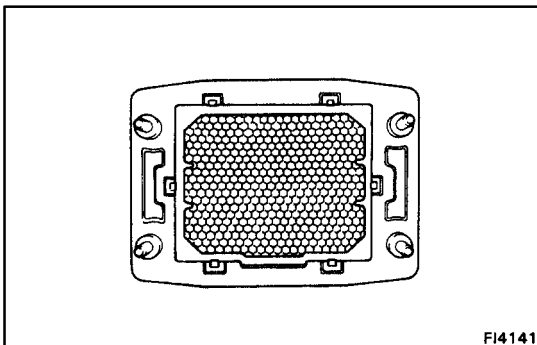

FI4141

INSPECTION OF AIR FLOW METER

Check that there is no deformation or damage to the honeycomb part.

If necessary, replace the air flow meter.

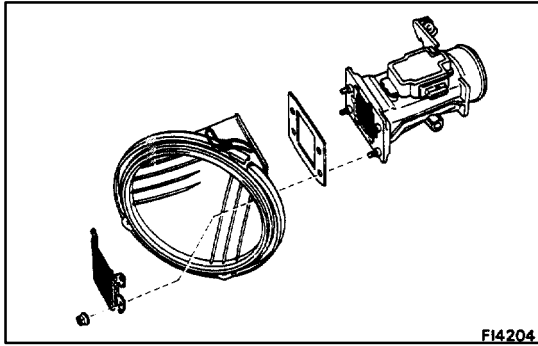

INSTALLATION OF AIR FLOW METER

1. INSTALL AIR FLOW METER

- (a) Install the gasket, air cleaner cap, protector and four nuts to the air flow meter.
- (b) Torque the four nuts.
Torque: 100 kg-cm (7 ft-lb, 10 N·m)
- (c) Bend the pawl to stop the nut from turning.

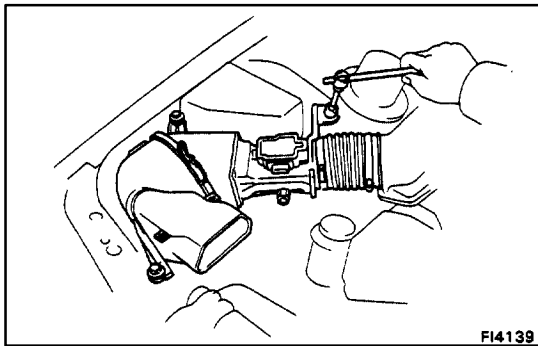

2. INSTALL AIR CLEANER WITH AIR FLOW METER

- (a) Install the air cleaner with air flow meter to the intake air connector pipe.
- (b) Install and torque the three bolts.
Torque: 50 kg-cm (43 in.-lb, 4.9 N·m)
- (c) Tighten the clamp.
- (d) Connect the connector to the air flow meter.

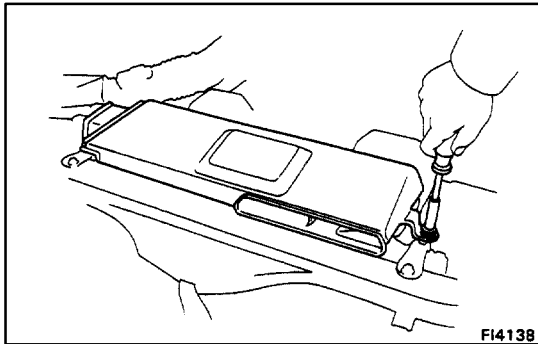

3. INSTALL NO.2 AIR CLEANER HOSE

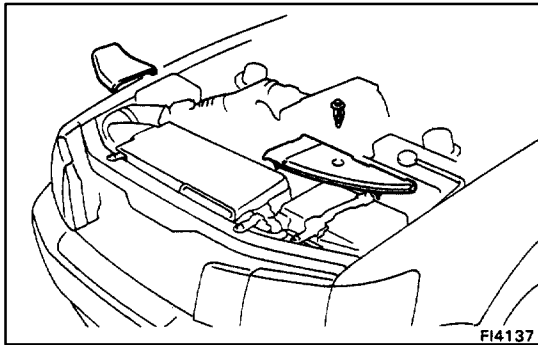

4. INSTALL AIR CLEANER COVER AND BATTERY CLAMP COVER