

## DESCRIPTION

### 1. OUTLINE OF AVC-LAN

#### (a) What is AVC-LAN?

AVC-LAN is the abbreviation for Audio Visual Communication-Local Area Network. This is a unified standard co-developed by 6 audio manufacturers associated with Toyota Motor Corporation.

The unified standard includes signals, such as audio, visual and signals for switch indication and communication.

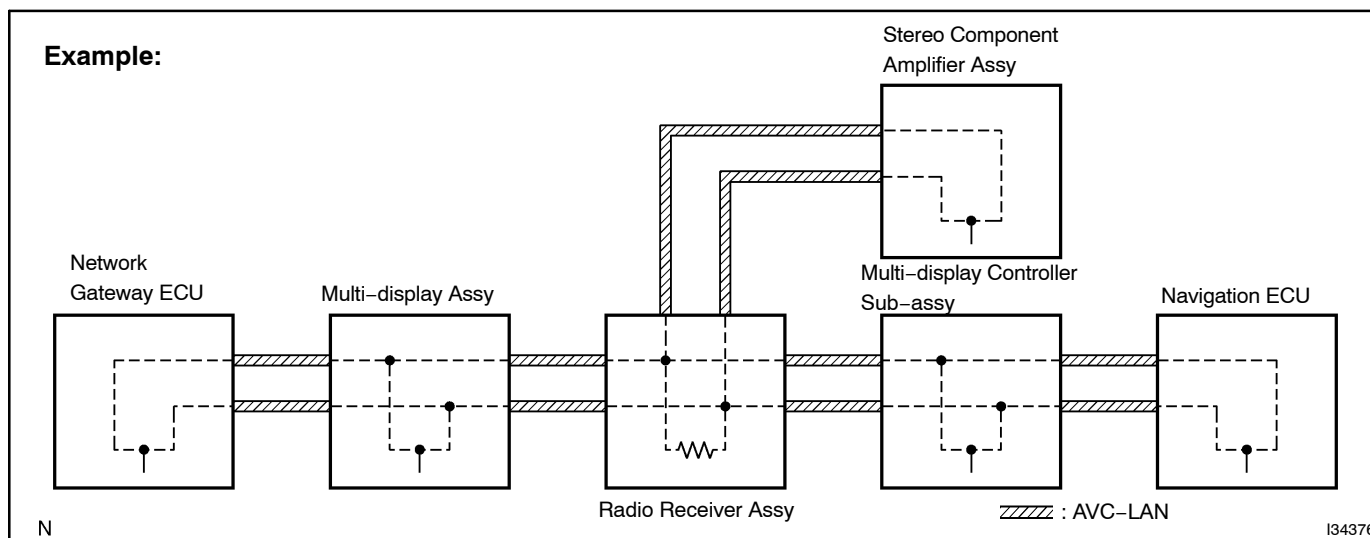

#### (b) Objectives

Recently developments in car audio systems have been rapid and functions have been changed drastically. The conventional system has been switched to the multi-media type such as a navigation system. At the same time customers want to upgrade their audio systems. This is the factor that lies behind this standardization.

The concrete objectives are explained below.

- (1) When products by different manufacturer were combined together, malfunctions such as sound failure occurred. This problem can be solved by standardization of signals.
- (2) Various types of after market products are available.
- (3) Because of the above (2), each manufacturer has been able to concentrate on developing products in their strongest field. This has enabled the development of inexpensive products.
- (4) In general, a new product developed by one particular manufacturer could not be used due to a lack of compatibility with other manufacturers products. By developing this new standard, users can enjoy a range of compatible products from different manufacturers anytime they want.

#### (c) The above stated are the reasons for the introduction of AVC-LAN. Under this standardization, development of new products no longer causes systematic errors.

#### HINT:

- When +B short or GND short is detected in AVC-LAN circuit, communication stops, and the audio system does not function normally.
- When audio system is not equipped with a navigation system, the audio head unit is the master unit. When the audio system is equipped with a navigation system, the radio receiver is the master unit.
- The master unit is equipped with a resistor (60 to 80  $\Omega$ ) for communication.
- The car audio system using AVC-LAN circuit has a diagnosis function.
- Each product has its own specified number called a physical address (three-digit number). Numbers are also allotted to each function within a product, which are called logical addresses (two-digit number).

## 2. COMMUNICATION SYSTEM

- (a) This system performs communication between the components through the AVC-LAN.

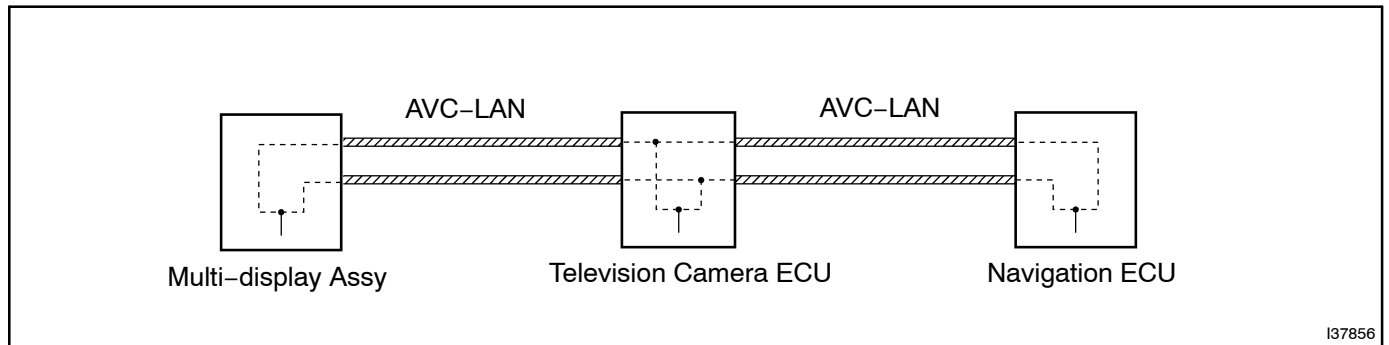

## 3. DIAGNOSIS FUNCTION

- (a) The multi-display assy functions as a master unit in the AVC-LAN circuit on this system. It identifies the trouble in this circuit, and the identified information is displayed on the multi-display assy.

HINT:

When performing the diagnosis check, refer to "LEXUS NAVIGATION SYSTEM" (See page 05-1509).

## 4. BACK MONITOR

- (a) Notes for back monitor.
- (1) The back monitor may not function properly if subjected to a severe blow by any hard object.
  - (2) Do not "scrub" the cover part of the camera (resin made). Scrubbing it may scratch the cover and affect the image. Prevent organic solvents, waxes, bond removing solvents, or glass coating from adhering to the cover. Clean off immediately, and wash with water.
  - (3) Exposing the camera to sudden temperature change may affect proper function.
  - (4) A clear image may not appear if the camera is dirty with snow, mud, etc. In that case, wash with water and wipe off. Use a detergent if necessary to remove dirt.
- (b) Images are difficult to discern even in normal conditions if:
- (1) Camera screen is frosted over (the image immediately after turning the ignition switch ON may be blurred or darker than normal).
  - (2) A strong beam of light, such as a sunbeam or headlight, hits the camera.
  - (3) It is too dark around the camera (at night etc.).
  - (4) The ambient temperature around the camera is either too high or too low.

HINT:

When a strong light, such as a sunbeam reflected off the vehicle's body, hits the camera, the image may be blurred. It is called the "SMEAR" phenomenon, peculiar to the CCD camera.