

Last Modified: 2-26-2020	6.10:8.0.50	Doc ID: RM000000W840QOX
Model Year Start: 2012	Model: GX460	Prod Date Range: [08/2011 -]
Title: A760F AUTOMATIC TRANSMISSION / TRANSAXLE: AUTOMATIC TRANSMISSION SYSTEM: P0705; Transmission Range Sensor Circuit Malfunction (PRNDL Input); 2012 MY GX460 [08/2011 -]		

DTC	P0705	Transmission Range Sensor Circuit Malfunction (PRNDL Input)
------------	--------------	--

DESCRIPTION

The Park/Neutral Position (PNP) switch detects the shift lever position and sends signals to the ECM.

DTC CODE	DTC DETECTION CONDITION	TROUBLE AREA
P0705	<p>One of the following conditions is met:</p> <p>(A) Any 2 or more of the following signals are ON simultaneously (2-trip detection logic):</p> <ul style="list-style-type: none"> • P input signal • N input signal • NSW input signal • R input signal • D input signal <p>(B) Any of the following signals is ON for 2.0 seconds or more with the shift lever in S (2-trip detection logic):</p> <ul style="list-style-type: none"> • P input signal • N input signal • NSW input signal • R input signal <p>(C) All signals are OFF simultaneously for NSW, P, R, N and D positions (2-trip detection logic).</p>	<ul style="list-style-type: none"> • Open or short in park/neutral position switch circuit • Park/neutral position switch • Transmission control switch (transmission floor shift assembly) • ECM

MONITOR DESCRIPTION

This DTC indicates a problem with the park/neutral position switch or the wire harness in the park/neutral position switch circuit.

The park/neutral position switch detects the shift lever position and sends a signal to the ECM.

For security, the park/neutral position switch detects the shift lever position so that the engine can be started only when the shift lever is in P or N.

The park/neutral position switch sends a signal to the ECM according to the shift lever position (P, R, N, D or S).

The ECM determines that there is a problem with the switch or related parts if it receives more than 1 position signal simultaneously. The ECM will illuminate the MIL and store the DTC.

MONITOR STRATEGY

Related DTCs	P0705: Park/neutral position switch/Verify switch input
Required sensors/Components	Park/neutral position switch
Frequency of operation	Continuous
Duration	Condition (A) and (B)

	2 seconds Condition (C) 60 seconds
MIL operation	2 driving cycles
Sequence of operation	None

TYPICAL ENABLING CONDITIONS

All

The monitor will run whenever the following DTCs are not present	None
Battery voltage	8 V or higher
Engine switch	On (IG)
Starter	OFF

TYPICAL MALFUNCTION THRESHOLDS

One of the following conditions is met: Condition (A), (B) or (C)

Condition (A)

When 2 or more of the following signals are input at the same time

P switch	ON
N switch	ON
NSW switch	ON
R switch	ON
D switch	ON

Condition (B)

When the shift lever is in S, one of the following conditions is met

P switch	ON
N switch	ON
NSW switch	ON
R switch	ON

Condition (C)

All of the following conditions are met

P switch	OFF
N switch	OFF
NSW switch	OFF
R switch	OFF
D switch	OFF

COMPONENT OPERATING RANGE

Park/neutral position switch	The park/neutral position switch sends only one signal to the ECM
------------------------------	---

WIRING DIAGRAM

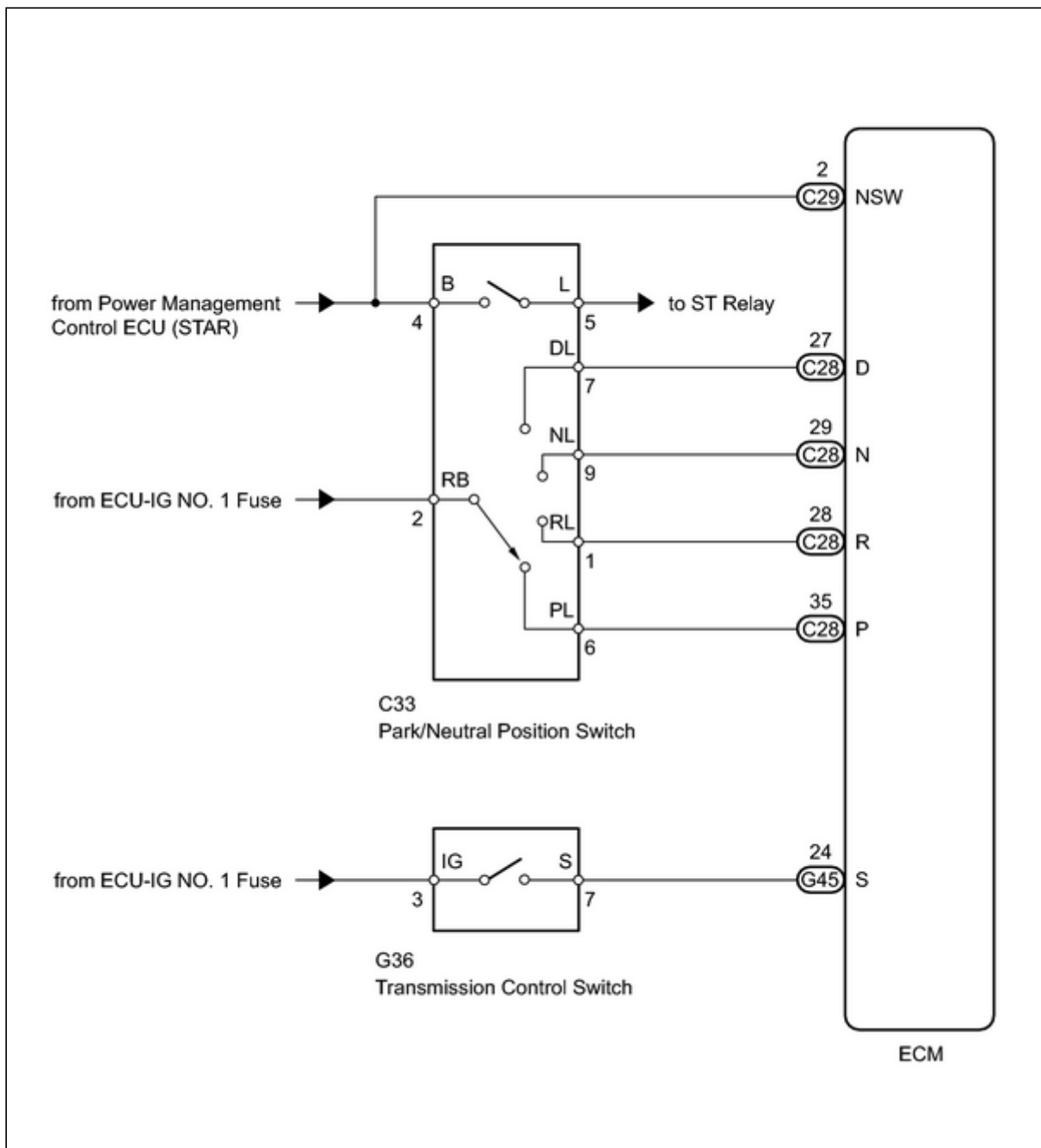

INSPECTION PROCEDURE

NOTICE:

Perform the universal trip to clear permanent DTCs [INFO](#) .

1. DATA LIST

HINT:

Using the Techstream to read the Data List allows the values or states of switches, sensors, actuators and other items to be read without removing any parts. This non-intrusive inspection can be very useful because intermittent conditions or signals may be discovered before parts or wiring is disturbed. Reading the Data List information early in troubleshooting is one way to save diagnostic time.

NOTICE:

In the table below, the values listed under "Normal Condition" are reference values. Do not depend solely on these reference values when deciding whether a part is faulty or not.

- (a) Warm up the engine.

- (b) Turn the engine switch off.
- (c) Connect the Techstream to the DLC3.
- (d) Turn the engine switch on (IG).
- (e) Turn the Techstream on.
- (f) Enter the following menus: Powertrain / Engine and ECT / Data List.
- (g) According to the display on the Techstream, read the Data List.

Engine and ECT

TESTER DISPLAY	MEASUREMENT ITEM/RANGE	NORMAL CONDITION	DIAGNOSTIC NOTE
Neutral Position SW Signal	PNP switch status/ ON or OFF	<ul style="list-style-type: none"> • ON: Shift lever in P or N • OFF: Shift lever not in P or N 	When the shift lever position displayed on the Techstream differs from the actual position, the adjustment of the PNP switch or shift cable may be incorrect.
Shift SW Status (P Range)	PNP switch status/ ON or OFF	<ul style="list-style-type: none"> • ON: Shift lever in P • OFF: Shift lever not in P 	When the shift lever position displayed on the Techstream differs from the actual position, the adjustment of the PNP switch or shift cable may be incorrect.
Shift SW Status (R Range)	PNP switch status/ ON or OFF	<ul style="list-style-type: none"> • ON: Shift lever in R • OFF: Shift lever not in R 	When the shift lever position displayed on the Techstream differs from the actual position, the adjustment of the PNP switch or shift cable may be incorrect.
Shift SW Status (N Range)	PNP switch status/ ON or OFF	<ul style="list-style-type: none"> • ON: Shift lever in N • OFF: Shift lever not in N 	When the shift lever position displayed on the Techstream differs from the actual position, the adjustment of the PNP switch or shift cable may be incorrect.
Sports Shift Up SW	Sport shift up switch status/ ON or OFF	<ul style="list-style-type: none"> • ON: Shift lever held in "+" (up-shift) • OFF: Shift lever not held in "+" (up-shift) 	-

TESTER DISPLAY	MEASUREMENT ITEM/RANGE	NORMAL CONDITION	DIAGNOSTIC NOTE
Sports Shift Down SW	Sport shift down switch status/ ON or OFF	<ul style="list-style-type: none"> • ON: Shift lever held in "-" (down-shift) • OFF: Shift lever not held in "-" (down-shift) 	-
Sports Mode Selection SW	Sport mode select switch status/ ON or OFF	<ul style="list-style-type: none"> • ON: Shift lever in S, "+" or "-" • OFF: Shift lever not in S, "+" or "-" 	-
Shift SW Status (D Range)	PNP switch status/ ON or OFF	<ul style="list-style-type: none"> • ON: Shift lever in D, S, "+" or "-" • OFF: Shift lever not in D, S, "+" or "-" 	When the shift lever position displayed on the Techstream differs from the actual position, the adjustment of the PNP switch or shift cable may be incorrect.

PROCEDURE

1.	INSPECT TRANSMISSION CONTROL SWITCH
-----------	--

(a) Disconnect the G36 transmission control switch connector.

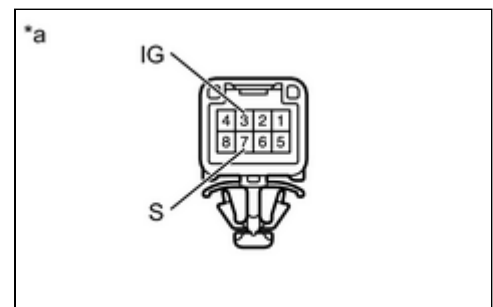

(b) Measure the resistance according to the value(s) in the table below.

Standard Resistance:

TESTER CONNECTION	CONDITION	SPECIFIED CONDITION
3 (IG) - 7 (S)	Shift lever in S, "+" or "-"	Below 1 Ω
3 (IG) - 7 (S)	Shift lever not in S, "+" or "-"	10 k Ω or higher

Text in Illustration

*a	Component without harness connected (Transmission Control Switch)
----	--

NG ▶ **REPLACE TRANSMISSION CONTROL SWITCH
(TRANSMISSION FLOOR SHIFT ASSEMBLY)**

OK



2.	CHECK TRANSMISSION CONTROL SWITCH (POWER SOURCE)
-----------	---

(a) Disconnect the G36 transmission control switch connector.

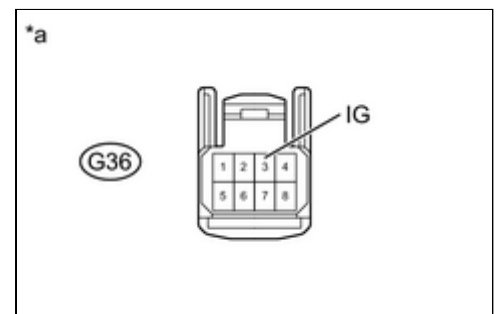

(b) Measure the voltage according to the value(s) in the table below.

Standard Voltage:

TESTER CONNECTION	SWITCH CONDITION	SPECIFIED CONDITION
G36-3 (IG) - Body ground	Engine switch on (IG)	11 to 14 V
G36-3 (IG) - Body ground	Engine switch off	Below 1 V

Text in Illustration

*a	Front view of wire harness connector (to Transmission Control Switch)
----	--

NG ▶ **REPAIR OR REPLACE HARNESS OR CONNECTOR
(TRANSMISSION CONTROL SWITCH - BATTERY)**

OK



3.	INSPECT PARK/NEUTRAL POSITION SWITCH ASSEMBLY
-----------	--

(a) Disconnect the C33 park/neutral position switch connector.

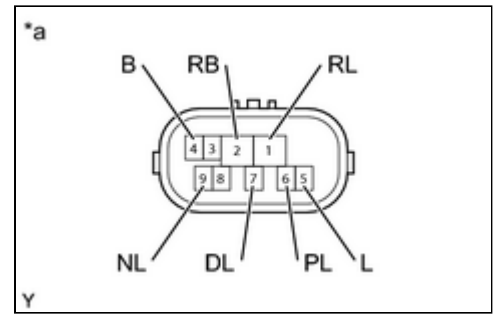

(b) Measure the resistance according to the value(s) in the table below.

Standard Resistance:

TESTER CONNECTION	CONDITION	SPECIFIED CONDITION
<ul style="list-style-type: none"> • 2 (RB) - 6 (PL) • 4 (B) - 5 (L) 	Shift lever in P	Below 1 Ω
2 (RB) - 1 (RL)	Shift lever in R	Below 1 Ω
<ul style="list-style-type: none"> • 2 (RB) - 9 (NL) • 4 (B) - 5 (L) 	Shift lever in N	Below 1 Ω
2 (RB) - 7 (DL)	Shift lever in D, S, "+" or "-"	Below 1 Ω
<ul style="list-style-type: none"> • 2 (RB) - 6 (PL) • 4 (B) - 5 (L) 	Shift lever not in P	10 kΩ or higher
2 (RB) - 1 (RL)	Shift lever not in R	10 kΩ or higher
<ul style="list-style-type: none"> • 2 (RB) - 9 (NL) • 4 (B) - 5 (L) 	Shift lever not in N	10 kΩ or higher
2 (RB) - 7 (DL)	Shift lever not in D, S, "+" or "-"	10 kΩ or higher

Text in Illustration

*a	Component without harness connected (Park/Neutral Position Switch)
----	---

NG **REPLACE PARK/NEUTRAL POSITION SWITCH ASSEMBLY**

OK



4.	CHECK PARK/NEUTRAL POSITION SWITCH ASSEMBLY (POWER SOURCE)
-----------	---

(a) Disconnect the C33 park/neutral position switch connector.

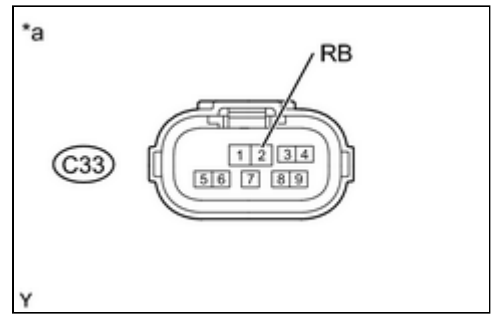

(b) Measure the voltage according to the value(s) in the table below.

Standard Voltage:

TESTER CONNECTION	SWITCH CONDITION	SPECIFIED CONDITION
C33-2 (RB) - Body ground	Engine switch on (IG)	11 to 14 V
C33-2 (RB) - Body ground	Engine switch off	Below 1 V

Text in Illustration

*a	Front view of wire harness connector (to Park/Neutral Position Switch)
----	---

NG ▶ REPAIR OR REPLACE HARNESS OR CONNECTOR
(PARK/NEUTRAL POSITION SWITCH - BATTERY)

OK

5. CHECK HARNESS AND CONNECTOR (PARK/NEUTRAL POSITION SWITCH - ECM)

(a) Disconnect the C28 and C29 ECM connectors.

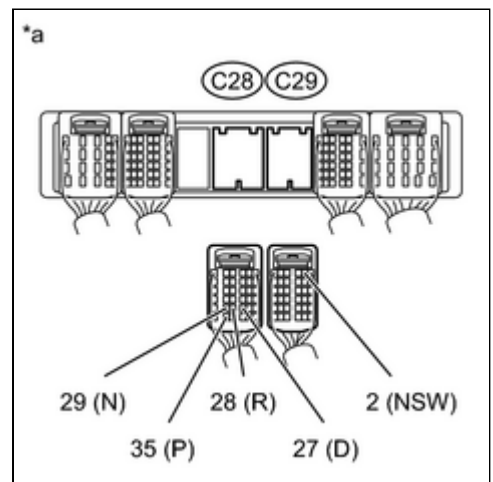

(b) Measure the voltage according to the value(s) in the table below.

Standard Voltage:

TESTER CONNECTION	CONDITION	SPECIFIED CONDITION

TESTER CONNECTION	CONDITION	SPECIFIED CONDITION
C28-35 (P) - Body ground	<ul style="list-style-type: none"> • Engine switch on (IG) • Shift lever in P 	11 to 14 V
C28-28 (R) - Body ground	<ul style="list-style-type: none"> • Engine switch on (IG) • Shift lever in R 	11 to 14 V*
C28-29 (N) - Body ground	<ul style="list-style-type: none"> • Engine switch on (IG) • Shift lever in N 	11 to 14 V
C28-27 (D) - Body ground	<ul style="list-style-type: none"> • Engine switch on (IG) • Shift lever in D 	11 to 14 V
C29-2 (NSW) - Body ground	<ul style="list-style-type: none"> • Engine switch on (IG) • Shift lever not in P or N 	11 to 14 V
C28-35 (P) - Body ground	<ul style="list-style-type: none"> • Engine switch on (IG) • Shift lever not in P 	Below 1 V
C28-28 (R) - Body ground	<ul style="list-style-type: none"> • Engine switch on (IG) • Shift lever not in R 	Below 1 V
C28-29 (N) - Body ground	<ul style="list-style-type: none"> • Engine switch on (IG) • Shift lever not in N 	Below 1 V
C28-27 (D) - Body ground	<ul style="list-style-type: none"> • Engine switch on (IG) • Shift lever not in D 	Below 1 V
C29-2 (NSW) - Body ground	<ul style="list-style-type: none"> • Engine switch on (IG) • Shift lever in P or N 	Below 1 V

Text in Illustration

*a	Front view of wire harness connector (to ECM)
----	--

HINT:

*: The voltage will drop slightly due to the illumination of the back-up light.

NG  **REPAIR OR REPLACE HARNESS OR CONNECTOR**

OK



6.	CHECK HARNESS AND CONNECTOR (TRANSMISSION CONTROL SWITCH - ECM)
-----------	--

(a) Disconnect the G45 ECM connector.

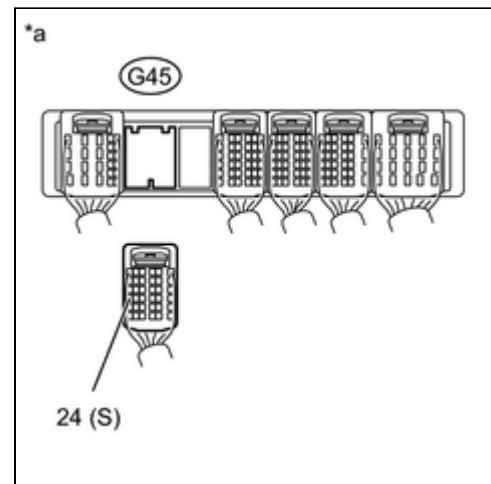

(b) Turn the engine switch on (IG).

(c) Measure the voltage according to the value(s) in the table below.

Standard Voltage:

TESTER CONNECTION	CONDITION	SPECIFIED CONDITION
G45-24 (S) - Body ground	Shift lever in S, "+" or "-"	11 to 14 V
G45-24 (S) - Body ground	Shift lever not in S, "+" or "-"	Below 1 V

Text in Illustration

*a	Front view of wire harness connector (to ECM)
----	---

NG ► REPAIR OR REPLACE HARNESS OR CONNECTOR

OK ► REPLACE ECM