

REAR VIEW MIRROR

DESCRIPTION

The '04 RX330 has a rear view mirror with following equipment:

Function		Destination	
		U.S.A.	Canada
Inside Rear View Mirror	Automatic Glare-resistant EC Mirror	STD	STD
	Compass Display	STD*1	STD*1
Outside Rear View Mirror	Electrical Remote Control	STD	STD
	Rear Window Defogger-Linked Mirror Heater and Front Wiper Deicer*2	STD	STD
	Automatic Glare-resistant EC Mirror	STD	STD
	Reverse Shift-Linked Mirror	OPT	OPT
	Memory Function	OPT	OPT

*1: Only for Models without LEXUS Navigation System

*2: Only for Canada Model

■ AUTOMATIC GLARE-RESISTANT EC MIRROR

1. General

During nighttime driving, if a large difference in intensity exists between the surrounding light and the light entering the inside rear view mirror from the headlights behind, automatic glare-resistant EC (Electrochromic) mirror automatically reduce the reflection rate of the inside rear view mirror and thus dampens the glare on the mirror. The reflection rate of the outside rear view mirrors varies in accordance with the change in the reflection rate of the inside rear view mirror.

- The inside and outside rear view mirrors are standard equipment.
- This system uses 2 sensors that are attached the inside rear view mirror to detect the difference between the intensity of light entering the inside rear view mirror from the rear of the vehicle.
- When the ignition switch is turned from OFF to ON, this system always turns on in the AUTO mode.

► System Diagram ◀

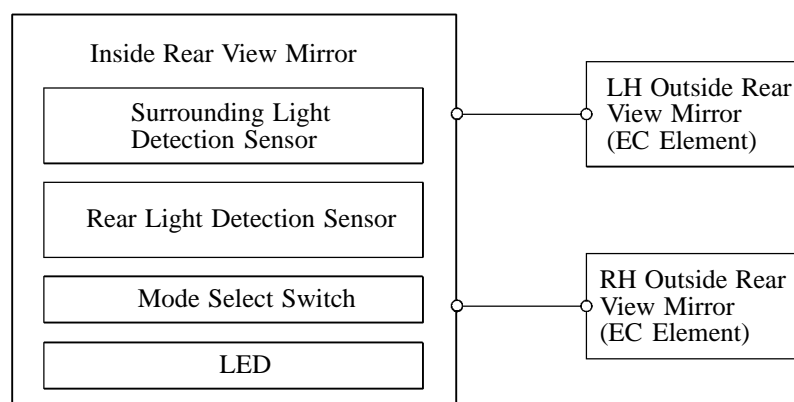

211BE45

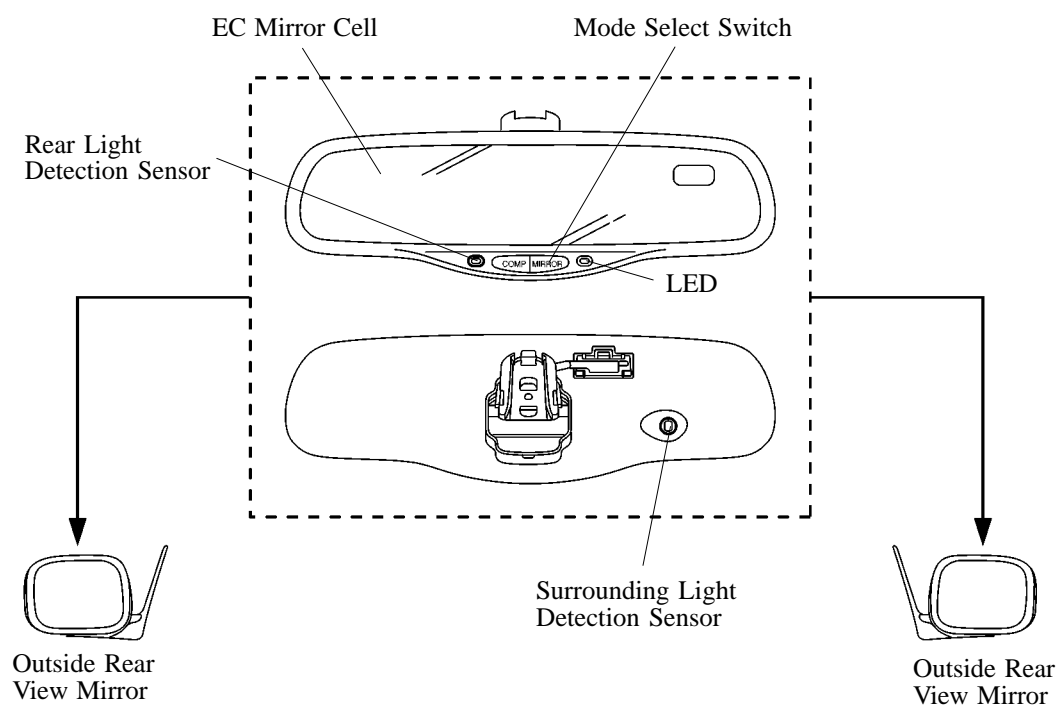

211BE46

2. Function of Components

General

Component	Function
Surrounding Light Detection Sensor	Detect the intensity of the light surrounding the vehicle.
Rear Light Detection Sensor	Detects the intensity of the light entering the inside rear view mirror from the rear of the vehicle.
LED	Turns on to inform the driver the AUTO mode is operating.
Mode Select Switch (AUTO, OFF)	Selects the inside and outside rear view mirror control to AUTO mode or AUTO OFF mode.
EC Mirror Cell	Varies the reflection rate of the mirror through the function of EC element.
CPU	Controls the reflection rate in accordance with the signals from the 2 sensors.

EC Mirror Cell

An EC mirror cell consists of 2 layers of glass, which sandwich the EC (Electrochromic) elements in the middle. The EC elements control coloring and discoloring characteristics through their electro-chemical oxidation reduce reaction. These characteristics are utilized to electronically vary the mirror's reflection rate.

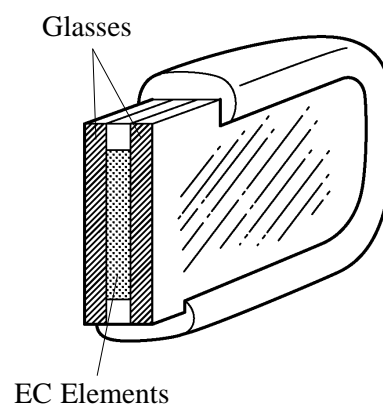

189BE55

3. Reflection Rate Control

This CPU detects the surrounding light through its surrounding light detection sensor, the rear light through its rear light detection sensor, and determines whether it is day or night through the intensity of the surrounding light. At the same time, the intensity of the glare from the rear determined through the difference in intensity between the surrounding and rear light. In accordance with the intensity of the rear light, the reflection rate varies steplessly.

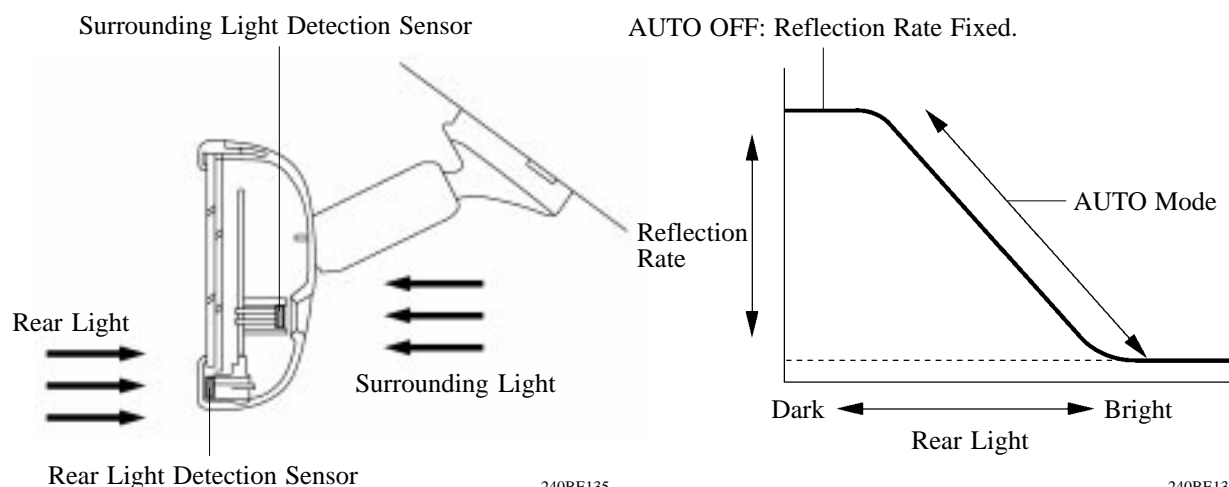

240BE135

240BE136

■ INSIDE REAR VIEW MIRROR

Compass Display

- A sensor which detects the earth magnetism has been built inside the mirror, that has less influence on the magnetization of the vehicle. Thus, the accuracy has been improved.
- The compass indicates the North as 0° and the forward direction of the vehicle by 8 azimuths.
- By operating the “COMP” switch, whether or not to indicate the compass, establishment of the compass zone and calibration can be performed.
- The compass display is not provided on models with a navigation system.

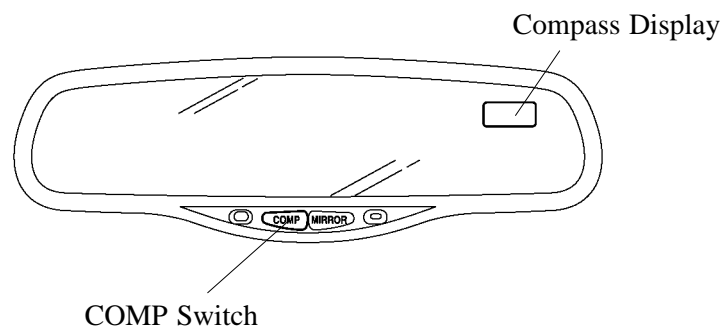

232BE61

► Compass Display ◀

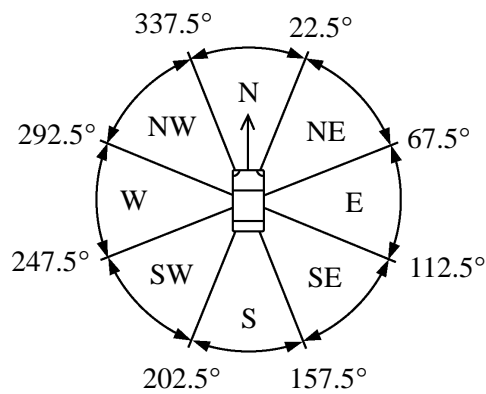

186BE05

		Display			
Calibration		C			
Calibration	Display	Calibration	Display	Calibration	Display
N	337.5° ~ 22.5°	N	157.5° ~ 202.5°	S	S
NE	22.5° ~ 67.5°	NE	202.5° ~ 247.5°	SW	SW
E	67.5° ~ 112.5°	E	247.5° ~ 292.5°	W	W
SE	112.5° ~ 157.5°	SE	292.5° ~ 337.5°	NW	NW

186BE06

Service Tip

As the compass system memorizes the vehicle’s marked magnetic field, it must be calibrated on each vehicle. Once it is calibrated, a recalibration is unnecessary unless a sudden change occurs in the magnetic field. If the magnetic field changes suddenly, the compass will display “C”, indicating that it must be recalibrated. For details, refer to the 2004 RX330 LEXUS Repair Manual (Pub. No. RM1027U).

■ OUTSIDE REAR VIEW MIRROR

1. General

- Electrical remote control mirrors with internal heater, which operate in conjunction with the rear window defogger and wiper deicer, have been adopted. Similar to the inside rear view mirror, automatic glare-resistant EC (Electrochromic) mirrors are standard equipment on the outside rear view mirrors.
- On the models with the memory system, the outside rear view mirrors are controlled by the remote control mirror ECU.
- On the models without the memory system, the positions of the outside rear view mirrors are controlled by the mirror control switch.
- The mirror heaters are controlled by the air conditioning ECU.

2. System Diagram

► Models without Memory System ◀

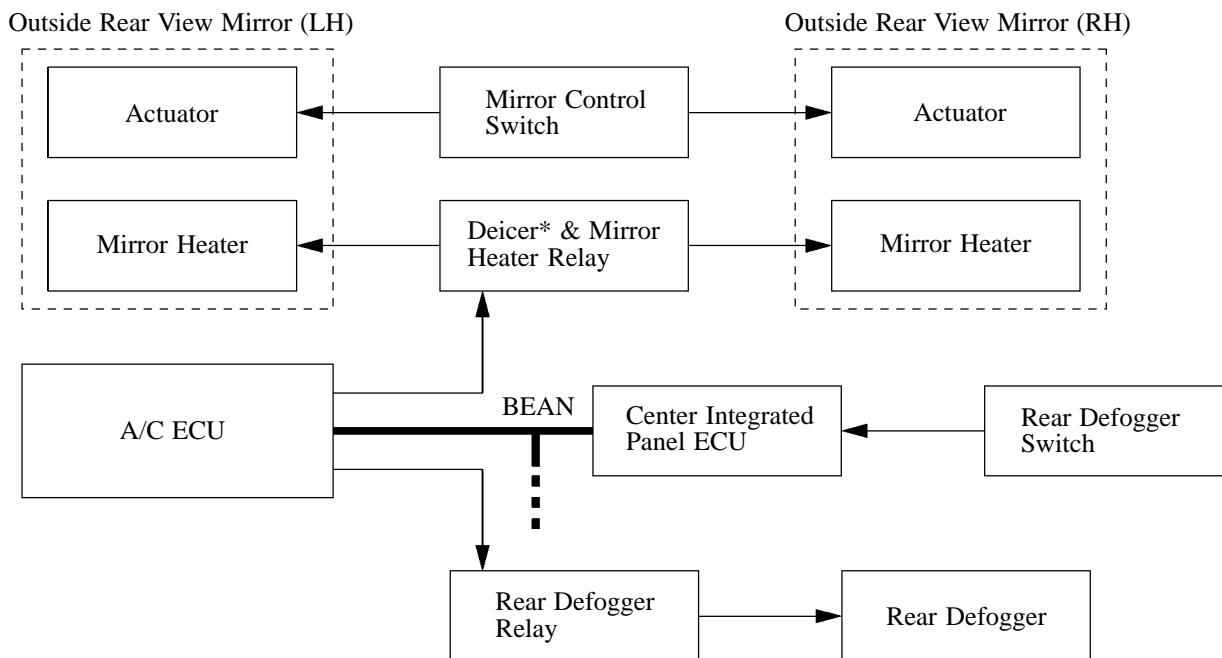

*: Only for Canada Model

► Models with Memory System ◀

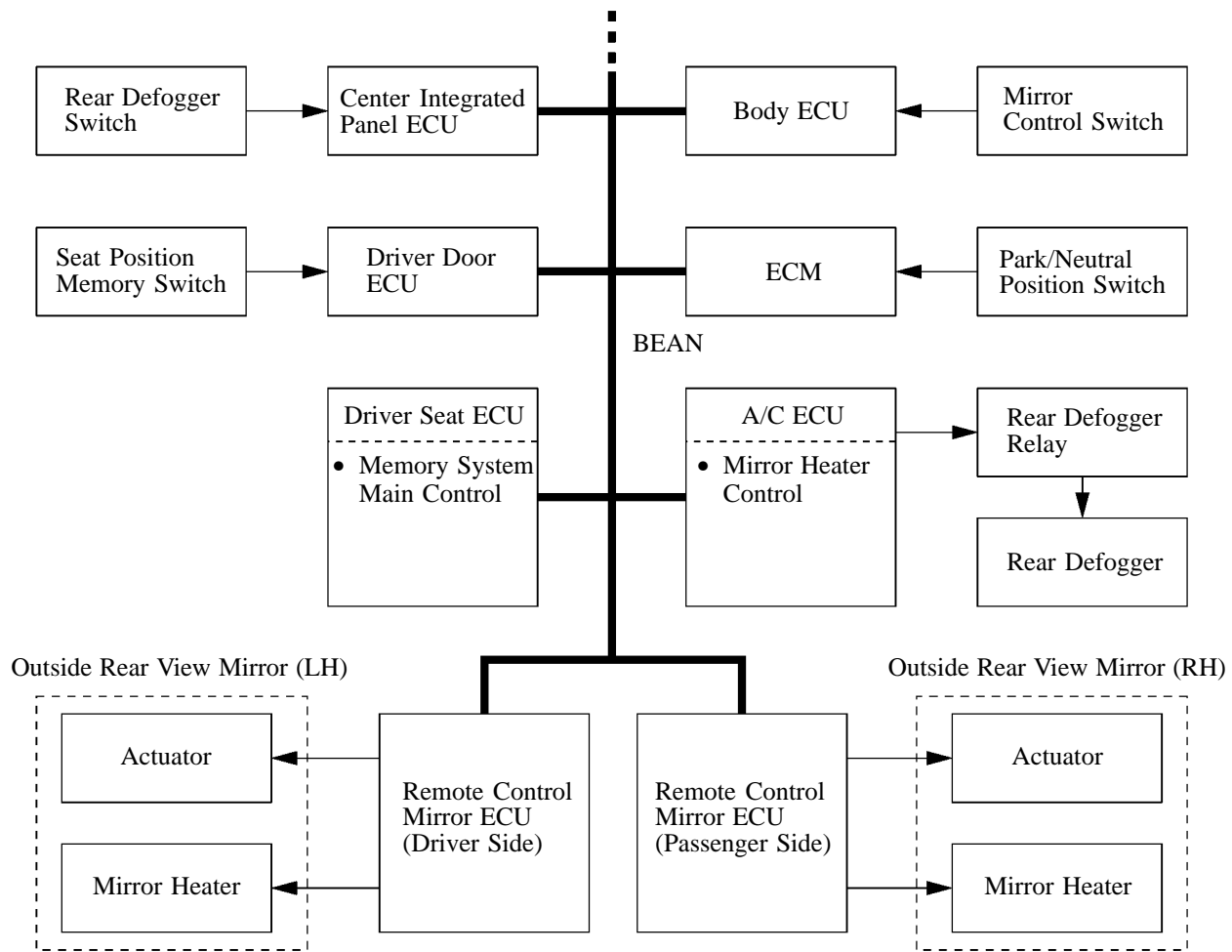

3. Function

The outside rear view mirror has following functions:

Function	Outline
Electrical Remote Control type Mirror	When the mirror control switch is operated, this function moves the mirror surface vertically or laterally to enable the driver to attain an optimal mirror angle. Setting the mirror master switch to the “R” position operates the right mirror, and to the “L” position operates the left mirror.
Rear Window Defogger-linked Mirror Heater and Front Wiper Deicer*1	This function also automatically turns ON the mirror heater (and front wiper deicer*1) when the rear window defogger switch is turned ON. After 15 minutes have elapsed from the time this function has been activated, the rear window defogger turns OFF automatically, and the mirror heater (and front wiper deicer*1) also turns OFF.
Automatic Glare-resistant EC Mirror	This function prevents the glare of the headlights of the vehicle being driven behind that are reflected on the mirror from blinding the driver during nighttime driving. It works in unison with the inner mirror to reduce the amount of reflection. For details, see page BE-172.
Reverse Shift-linked Mirror*2	This function directs the mirror surface downward to improve the visibility when driving in reverse, provided that all the conditions given below have been met. <ul style="list-style-type: none"> • Ignition switch is ON. • Shift lever is moved from a position other than “R” to “R”. • Mirror master switch is in “R” or “L” position.
Memory Function*2	This function stores 2 mirror adjustment positions in the remote control mirror ECU. Thus, the mirrors can be adjusted to the positions that are stored in the remote control mirror ECU by pressing the memory switch. This function operates by linking with the driver seat position memorized in the driver seat ECU. For details, see page BE-166.

*1: Only for Canada Model

*2: Models with Memory System