

DTC	B1153/25	SEAT POSITION AIRBAG SENSOR MALFUNCTION
------------	-----------------	--

CIRCUIT DESCRIPTION

The seat position airbag sensor circuit consists of the airbag sensor assy center and the seat position airbag sensor.

DTC B1153/25 is recorded when a malfunction is detected in the seat position airbag sensor circuit.

DTC No.	DTC Detecting Condition	Trouble Area
B1153/25	When one of the following conditions is met: • The airbag sensor assy center detects a line short signal, open signal, short to ground signal, or short to B+ signal in the seat position airbag sensor circuit. • Seat position airbag sensor malfunction • Airbag sensor assy center malfunction	• Seat position airbag sensor • Airbag sensor assy center • Front seat inner belt assy LH • Floor wire No.2

WIRING DIAGRAM

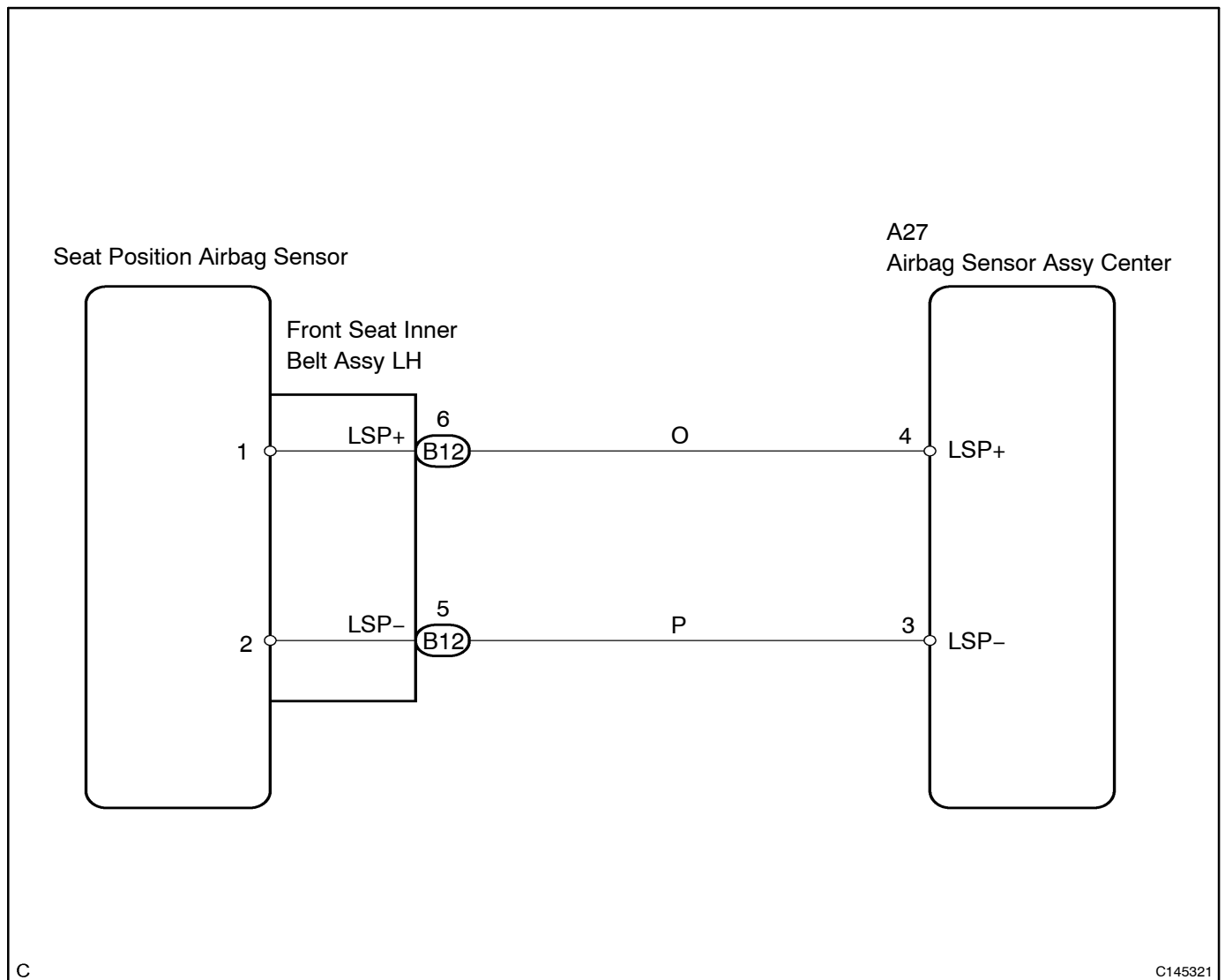

C

C145321

INSPECTION PROCEDURE

1 CHECK DTC

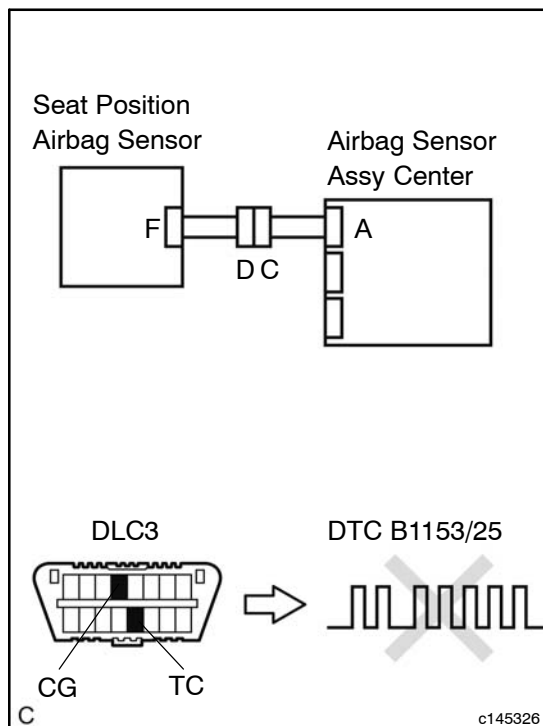

- Turn the ignition switch to the ON position, and wait at least for 60 seconds.
- Clear the DTCs stored in memory (See page 05-973).
- Turn the ignition switch to the LOCK position.
- Turn the ignition switch to the ON position, and wait for at least 60 seconds.
- Check the DTCs (See page 05-973).

OK:

DTC B1153/25 is not output.

HINT:

Codes other than code B1153/25 may be output at this time, but they are not related to this check.

NG →

GO TO STEP 2

OK

USE SIMULATION METHOD TO CHECK

2 CHECK CONNECTORS

- Turn the ignition switch to LOCK position.
- Disconnect the negative (-) terminal cable from the battery, and wait for at least 90 seconds.
- Check that the connectors are properly connected to the airbag sensor assy center, seat position airbag sensor and front seat inner belt assy LH.

OK:

The connectors are properly connected.

HINT:

If the connectors are not connected securely, reconnect the connectors and proceed to the next inspection.

- Disconnect the connectors from the airbag sensor assy center, seat position airbag sensor and front seat inner belt assy LH.
- Check that the terminals of the connectors are not damaged.

OK:

The terminals are not deformed or damaged.

NG →

REPLACE WIRE HARNESS OR CONNECTORS

OK

3 CHECK SEAT POSITION AIRBAG SENSOR CIRCUIT (OPEN)

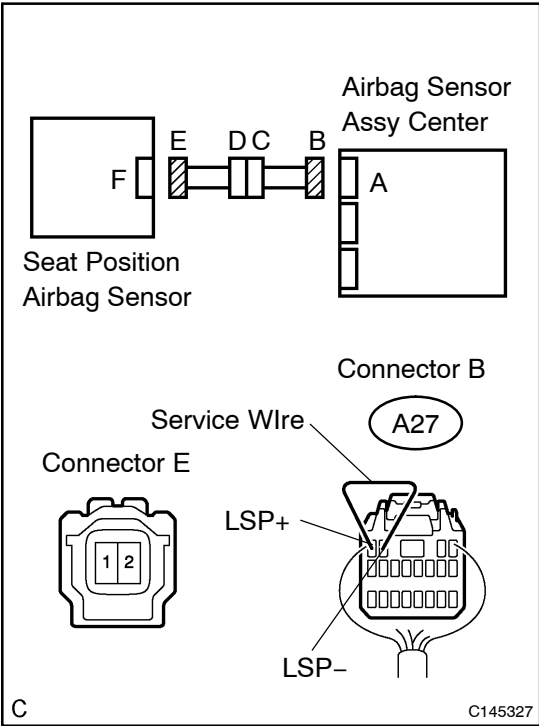

- (a) Using a service wire, connect A27-4 (LSP+) and A27-3 (LSP-) of connector B.

NOTICE:
Do not forcibly insert a service wire into the terminals of the connector when connecting.

- (b) Measure the resistance between the terminals of connector E according to the value(s) in the table below.

Standard resistance:

Tester connection	Condition	Specified condition
1 - 2	Always	Below 1 Ω

NG → **GO TO STEP 10**

OK

4 CHECK SEAT POSITION AIRBAG SENSOR CIRCUIT (SHORT TO GROUND)

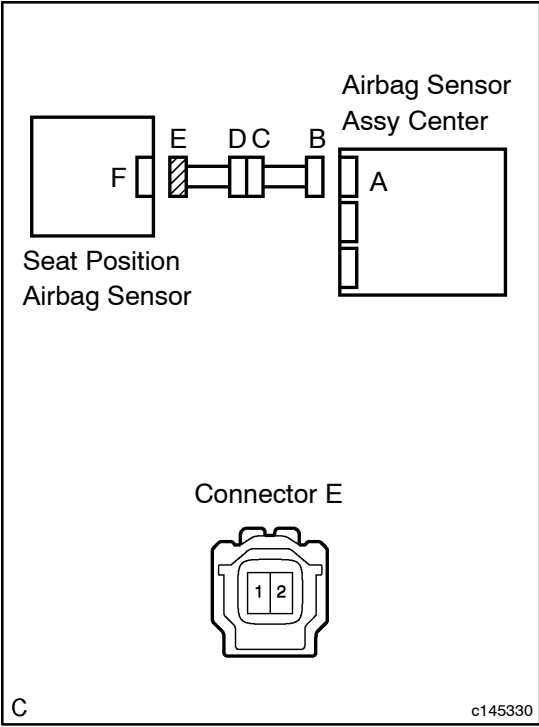

- (a) Disconnect the service wire from connector B.
- (b) Measure the resistance according to the value(s) in the table below.

Standard resistance:

Tester connection	Condition	Specified condition
1 - Body ground	Always	1 MΩ or higher
2 - Body ground	Always	1 MΩ or higher

NG → **GO TO STEP 11**

OK

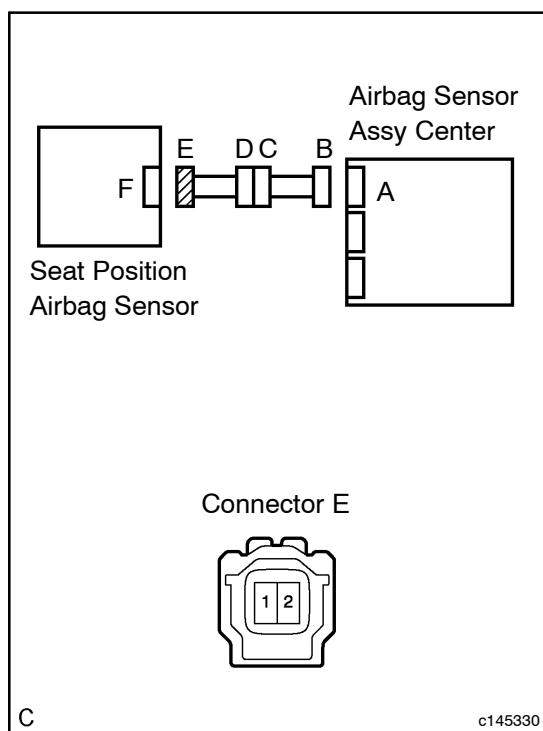
5 CHECK SEAT POSITION AIRBAG SENSOR CIRCUIT (SHORT)

- (a) Measure the resistance according to the value(s) in the table below.

Standard resistance:

Tester connection	Condition	Specified condition
1 - 2	Always	1 MΩ or higher

NG → GO TO STEP 12

OK

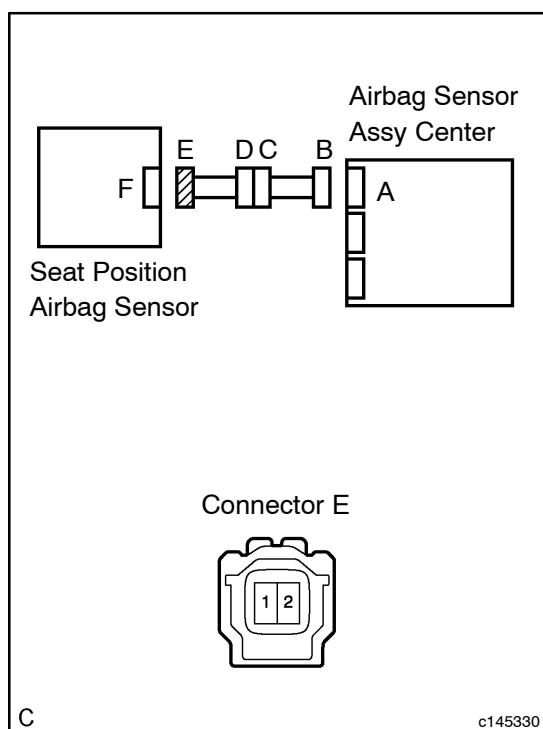
6 CHECK SEAT POSITION AIRBAG SENSOR CIRCUIT (SHORT TO B+)

- (a) Deactivate the LEXUS link system (See page 05-973).
 (b) Connect the negative (-) terminal cable to the battery, and wait for at least 2 seconds.
 (c) Turn the ignition switch to the ON position.
 (d) Measure the voltage according to the value(s) in the table below.

Standard voltage:

Tester connection	Condition	Specified condition
1 - Body ground	Ignition switch ON	Below 1 V
2 - Body ground	Ignition switch ON	Below 1 V

NG → GO TO STEP 13

OK

7 CHECK SEAT POSITION AIRBAG SENSOR

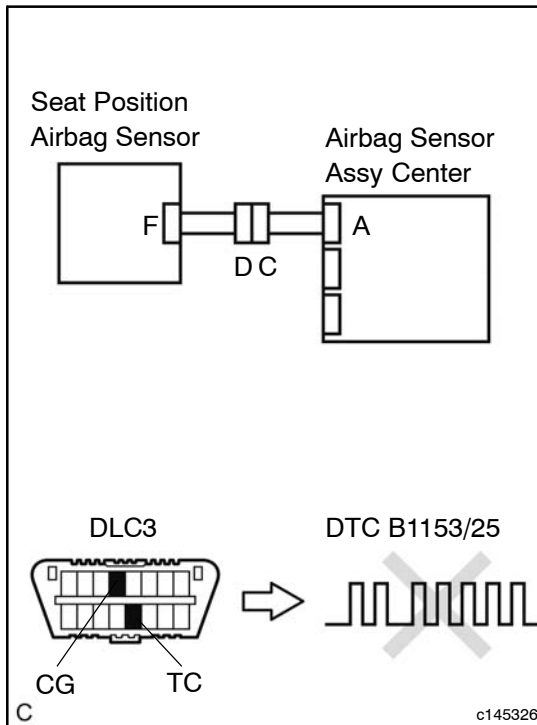

- (a) Turn the ignition switch to the LOCK position.
- (b) Disconnect the negative (-) terminal cable from the battery, and wait for at least 90 seconds.
- (c) Connect the connectors to the seat position airbag sensor and the airbag sensor assy center.
- (d) Connect the negative (-) terminal cable to the battery, and wait for at least 2 seconds.
- (e) Turn the ignition switch to the ON position, and wait for at least 60 seconds.
- (f) Clear the DTCs stored in memory (See page 05-973).
- (g) Turn the ignition switch to the LOCK position.
- (h) Turn the ignition switch to the ON position, and wait for at least 60 seconds.
- (i) Check the DTCs (See page 05-973).

OK:

DTC B1153/25 is not output.

HINT:

Codes other than code B1153/25 may be output at this time, but they are not related to this check.

NG → **GO TO STEP 8**

OK

USE SIMULATION METHOD TO CHECK

8 REPLACE SEAT POSITION AIRBAG SENSOR

- (a) Turn the ignition switch to the LOCK position.
- (b) Disconnect the negative (-) terminal cable from the battery, and wait for at least 90 seconds.
- (c) Replace the seat position airbag sensor (See page 60-61)

HINT:

Perform the inspection using parts from a normal vehicle if possible.

NEXT

9 CHECK AIRBAG SENSOR ASSY CENTER

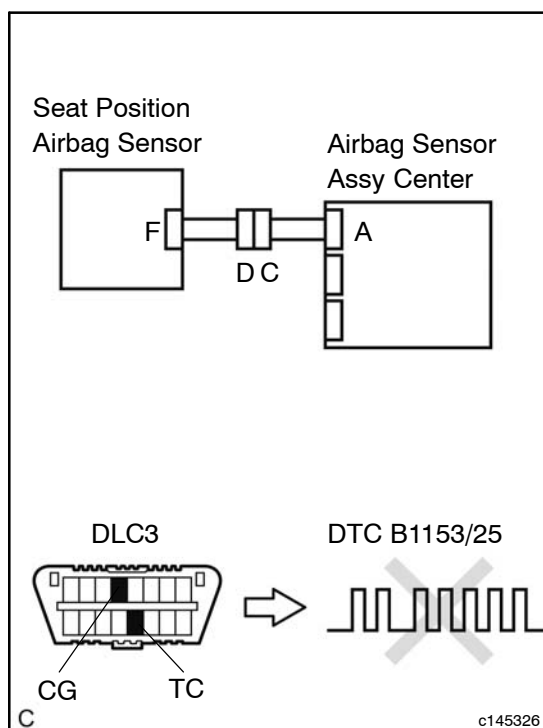

- Connect the negative (-) terminal cable to the battery, and wait for at least 2 seconds.
- Turn the ignition switch to the ON position, and wait for at least 60 seconds.
- Clear the DTCs stored in memory (See page 05-973).
- Turn the ignition switch to the LOCK position.
- Turn the ignition switch to the ON position, and wait for at least 60 seconds.
- Check the DTCs (See page 05-973).

OK:

DTC B1153/25 is not output.

HINT:

Codes other than code B1153/25 may be output at this time, but they are not related to this check.

NG

**REPLACE AIRBAG SENSOR ASSY CENTER
(SEE PAGE 60-52)**

OK

10 CHECK FLOOR WIRE NO.2 (OPEN)

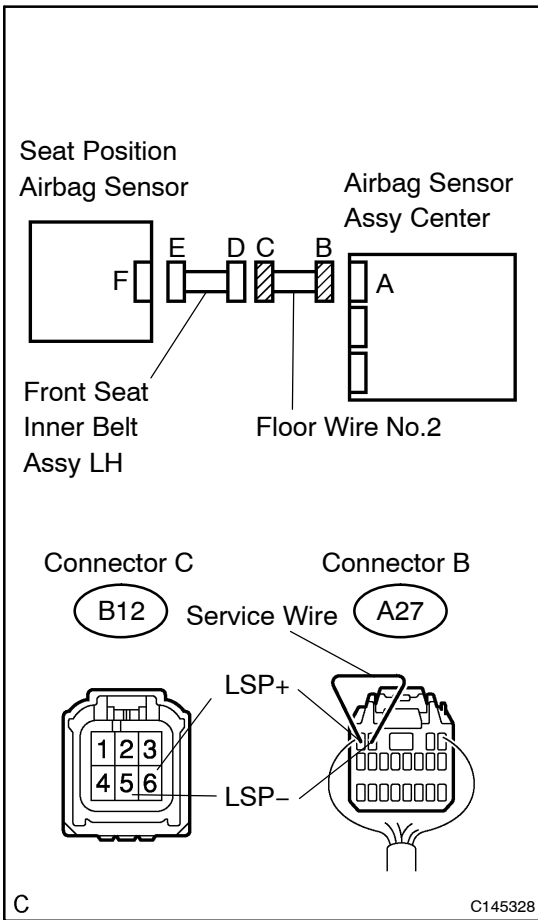

(a) Disconnect the front seat inner belt assy LH connector from the floor wire No.2 connector.

HINT:

The service wire has already been inserted into connector B.

(b) Measure the resistance according to the value(s) in the table below.

Standard resistance:

Tester connection	Condition	Specified condition
B12-6 (LSP+) - B12-5 (LSP-)	Always	Below 1 Ω

NG → **REPLACE FLOOR WIRE NO.2**

OK

REPLACE FRONT SEAT INNER BELT ASSY LH

11 CHECK FLOOR WIRE NO.2 (SHORT TO GROUND)

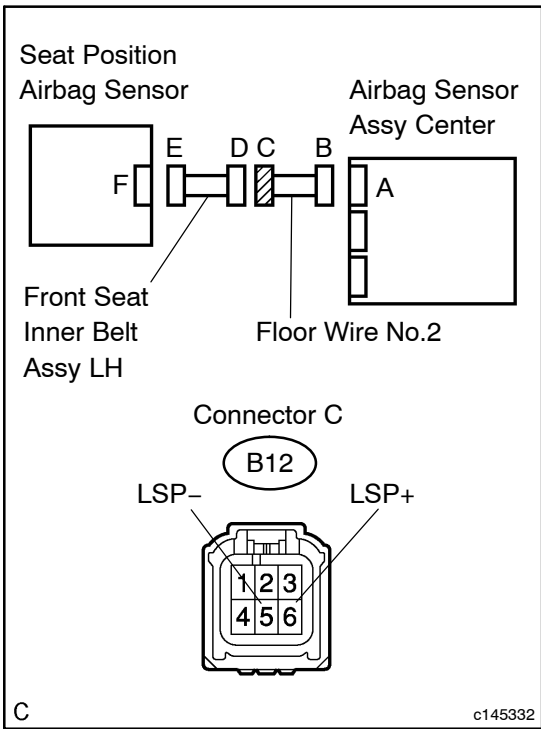

- (a) Disconnect the front seat inner belt assy LH connector from the floor wire No.2 connector.
- (b) Measure the resistance according to the value(s) in the table below.

Standard resistance:

Tester connection	Condition	Specified condition
B12-6 (LSP+) - Body ground	Always	1 MΩ or higher
B12-5 (LSP-) - Body ground	Always	1 MΩ or higher

NG → **REPLACE FLOOR WIRE NO.2**

OK

REPLACE FRONT SEAT INNER BELT ASSY LH

12 CHECK FLOOR WIRE NO.2 (SHORT)

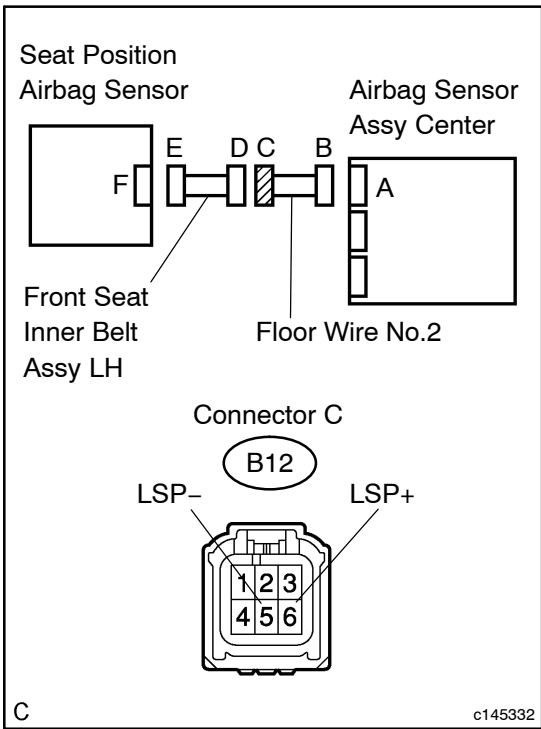

- (a) Disconnect the front seat inner belt assy LH connector from the floor wire No.2 connector.
- (b) Measure the resistance according to the value(s) in the table below.

Standard resistance:

Tester connection	Condition	Specified condition
B12-6 (LSP+) - B12-5 (LSP-)	Always	1 MΩ or higher

NG → **REPLACE FLOOR WIRE NO.2**

OK

REPLACE FRONT SEAT INNER BELT ASSY LH

13 CHECK FLOOR WIRE NO.2 (SHORT TO B+)

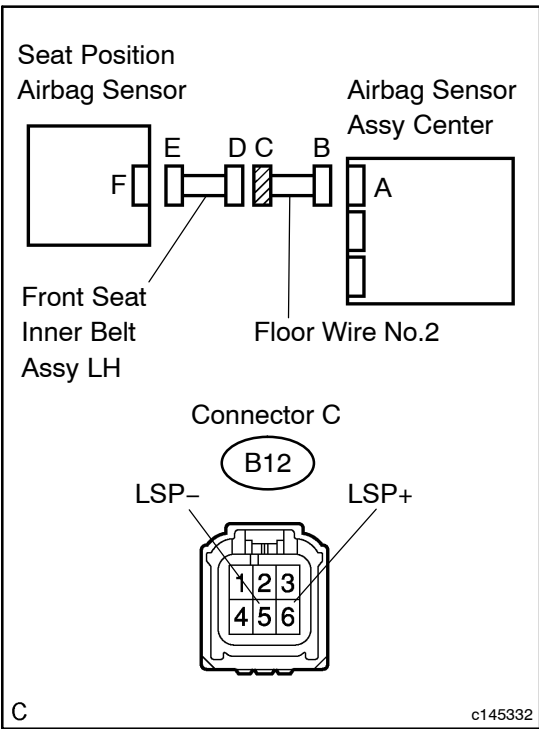

- (a) Turn the ignition switch to the LOCK position.
- (b) Disconnect the negative (-) terminal cable from the battery, and wait for at least 90 seconds.
- (c) Disconnect the front seat inner belt assy LH connector from the floor wire No.2 connector.
- (d) Connect the negative (-) terminal cable to the battery, and wait for at least 2 seconds.
- (e) Turn the ignition switch to the ON position.
- (f) Measure the voltage according to the value(s) in the table below.

Standard voltage:

Tester connection	Condition	Specified condition
B12-6 (LSP+) - Body ground	Ignition switch ON	Below 1 V
B12-5 (LSP-) - Body ground	Ignition switch ON	Below 1 V

NG **REPLACE FLOOR WIRE NO.2**

OK

REPLACE FRONT SEAT INNER BELT ASSY LH